

INNOVATION IN HYBRID MASS TIMBER CONSTRUCTION

# TALLWOOD BU

BROCK COMMONS TALLWOOD HOUSE  
PERFORMANCE OVERVIEW

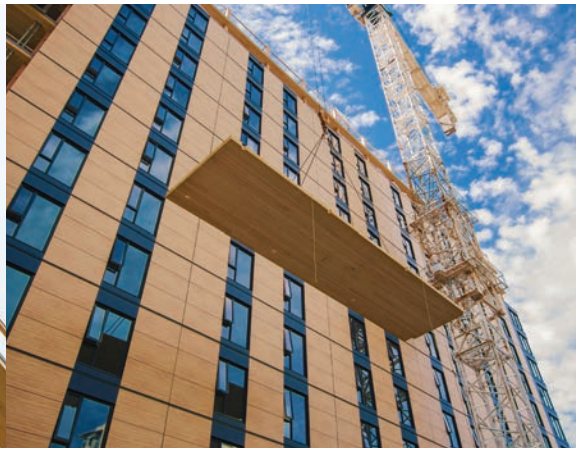



*“Brock Commons Tallwood House is a shining star within UBC’s overall inventory of student housing facilities. Early feedback from the first group of student residents is very positive; many residents emphasize the comfort, warmth, and excellent acoustic qualities they experience residing there. We are proud of the innovation and to support the wood industry in British Columbia—not to mention the ‘tallest mass timber building in the world’ status the building is able to boast!”*

MANAGING DIRECTOR, UBC STUDENT HOUSING AND HOSPITALITY SERVICES





## INTRODUCTION

With more than four hundred hectares of land, a daytime population of about 70,000 (students, staff, and faculty), and close to 20,000 student residents the Vancouver campus of the University of British Columbia (UBC) is the size of a small city. This gives the university a unique opportunity to combine its teaching and research interests with its operational needs to demonstrate and advance innovative and sustainable solutions in the built environment. In 2017, UBC completed Brock Commons Tallwood House, an 18-storey student residence and, at 54 metres in height, the tallest mass timber hybrid building in the world at the time of construction.

Tallwood House was one of the demonstration projects in the 2013 Tall Wood Building Demonstration Initiative competition. The competition aimed to advance the design and production of engineered wood products in Canada and demonstrate that wood is a viable structural option for mid-rise and high-rise buildings. The project was a success, delivered on time and on budget.

Tallwood House is the first building in a planned student residential complex. It includes 404 student beds in studios and four-bed units, study and social spaces on the ground floor, and a student lounge on the top floor. The building has an innovative hybrid structure. The foundation, ground floor, second-floor slab, and stair/elevator cores are cast-in-place concrete, while the superstructure is composed of prefabricated cross-laminated timber (CLT) panel floor assemblies supported on glue-laminated timber (GLT) and parallel strand lumber (PSL) columns with steel connections, and a steel roof deck with a traditional SBS (styrene-butadiene-styrene) roof assembly. The building envelope is comprised of

prefabricated, steel-stud frame panels with wood-fibre laminate cladding. The mass timber is encapsulated with three or four layers of fire-rated gypsum boards for fire protection.

The project team incorporated both innovative approaches and well-established procedures to ensure the quality and performance of the building. For example, they utilized an integrated design process that engaged key design and construction consultants and trades. They also incorporated a virtual design and construction model, which enabled a high degree of precision in the positioning and alignment of different building systems and components, while project specifications and other design documents were used to establish clear expectations for the quality assurance and quality control processes in the fabrication and construction phases. These requirements referenced existing Canadian or North American building standards, although more stringent requirements were used to account for the unprecedented height of the structure and tight tolerances for prefabrication. The project architect was responsible for the coordination of document and field reviews and UBC building permit authorities were responsible for inspections to verify compliance with the performance requirements.

Because mass timber is a new product for the structure of high-rise buildings, the performance of the Tallwood House project was closely assessed in terms of costs, environmental impacts, and inhabitant comfort and satisfaction. This data, while valuable for the Tallwood House project, will also be used to inform the development of future tall wood building projects.

### FACTS

---

- Height is 54 m (18 storeys)
  - Site area is 2,315 m<sup>2</sup>
  - Gross area is 15,120 m<sup>2</sup>
  - Footprint is about 15×56 m, totalling 840 m<sup>2</sup>
  - Typical floor-to-floor height is 2.81 m for the mass timber structure on the upper floors, and 5 m on the ground floor
- 

#### FRONT COVER

KK Law  
Pollux Chung  
Fast + Epp  
Michael Elkan

#### BACK COVER

Michael Elkan

## PERFORMANCE OF STRUCTURAL ELEMENTS

Brock Commons Tallwood House was built in accordance with the *British Columbia Building Code 2012* under the site-specific regulation, *UBC Tall Wood Building Regulation*, which sets requirements for the building to meet or exceed the performance of a comparable non-combustible building.<sup>1</sup> As part of the site-specific regulation approval process, the overall design and modelling of the structure were peer reviewed by independent certified engineers and by an expert panel. This approval process helped establish the design parameters and ensured the incorporation of extra safety protection measures for the mass timber during the design, construction, and operation of the building.

The site-specific regulation required the ground floor and two stair/elevator cores be made of concrete. The cores play an important role in the seismic performance of the building—they support the lateral loads that are transferred from the CLT floor panel via steel drag strap connections and, in turn, provide resistance to these lateral loads. The cores transfer the loads to the concrete foundation below.

The site-specific regulation also required that the structural design follow the not-yet-adopted *National Building Code of Canada 2015* (NBCC 2015). The NBCC 2015 performance standards include seismic acceleration values (the anticipated speed of movement during an earthquake that the building must withstand) that are about 50% higher than the current *British Columbia Building Code 2012*. The improvements in seismic resistance were achieved through design approaches, such as using more rebar in specific locations within the concrete cores. Accelerometers attached to CLT panels on levels nine and 18 and a GPS device on the roof provide ongoing data on lateral movement and vibration caused by seismic events and wind.

---

<sup>1</sup>“Brock Commons Tallwood House: Code Compliance”, [naturallywood.com](http://naturallywood.com)



### MASS TIMBER ELEMENTS

In North America there is an established and growing market for mass timber products. This market is supported by standards and certifications that dictate the quality and performance of engineered wood building elements and the companies producing and installing them. Among other things, the standards prescribe the production facility requirements and personnel qualifications, manufacturing processes and equipment, product quality and details, and tests, inspection and quality control processes. These market standards were referred to in Tallwood House's project specifications and other contract requirements to ensure that the manufacturers and trades were qualified and could meet the fabrication and installation expectations.

Given the unprecedented height of the building, the structural engineer required the performance of the CLT floor panels to exceed the accepted standards so as to ensure their safe structural functionality. This was achieved by specifying higher grades of lumber (which have higher strength and elasticity) for the laminate layers of the CLT panels.

To validate the design assumptions and to evaluate the quality of the products, 18 CLT panels from prospective suppliers were tested under full-scale loads in the lab. The test results showed that the load-bearing capacity of the CLT panels was significantly higher than had been assumed in North American CLT structural performance standards and met the design specifications for Tallwood House.

The structural engineer also conducted a series of field reviews to ensure that the structural elements complied with the site-specific regulation, industry standards, and project specifications. The reviews evaluated the prefabrication and construction as well as details such as positioning of reinforcing and quality assurance measures, including conducting cylinder break tests to assess the compressive strength of the concrete. The reviews also assessed the installation of the mass timber elements in every floor, particularly the connections and fastenings between the columns, the CLT panels, the cores, and the second level concrete transfer slab.<sup>2</sup>

---

<sup>2</sup> "Brock Commons Tallwood House: Design & Preconstruction Overview", [naturallywood.com](http://naturallywood.com)

### FABRICATION AND INSTALLATION

While it expedited the construction process, prefabrication of multiple building elements required a high degree of manufacturing and installation precision and coordination among the various project team members. Both of these factors were enabled by the intensive use of virtual design and construction (VDC) modelling. All the building components, including the mass timber elements, steel connections, envelope panels, and mechanical and electrical systems were modelled in full detail. The manufacturer used the digital files converted from the VDC model (which contained the exact CLT panel dimensions and cutouts for the mechanical system penetration) to fabricate the components by computer numerical control (CNC) machines, maintaining precision and minimizing typical discrepancies that might occur using conventional ways of converting modelling plans to fabrication specifications.

In addition to the VDC model, a full-scale mock-up of a section of the ground floor and typical upper floor was built during the design phase. The mock-up tested the feasibility and accuracy of multiple connection designs, material choices, and installation methods. Testing the design innovations in advance reduced the likelihood of errors and construction challenges that would normally have been experienced on site.

As a standard practice in mass timber construction, the Tallwood House project specifications required the fabricator and erector to submit detailed production and installation documentation for review by the design team. These included submission of shop drawings by the manufacturer for all the elements and an installation method statement from the erector. The shop drawings allocated a unique identifier to each mass timber element, which tracked each piece to its specific location on the building and avoided misplacement during installation on site. Having these details in advance was particularly important for the CLT panels as they came with the specific cutouts for the building systems.

The project specifications included more stringent tolerances for the mass timber elements than those specified in the North American standards for the production of mass timber. This was necessary given the size of the project as small dimensional errors could add up and create significant variations in floor heights and misalignment along the floor perimeters. Despite the higher level of production and installation accuracy required, neither the mass timber manufacturer nor the erector required any considerable change to their existing equipment, training, or processes.

### CLT FABRICATION TOLERANCE IN TALLWOOD HOUSE VS. STANDARDS

	Tallwood House Specifications	ANSI/APA/PRG 320*
Thickness	1.6 mm	1.6 mm
Width	2 mm	3.2 mm
Length	2 mm	6.4 mm
Squareness	2 mm	3.2 mm
Straightness	1 mm	1.6 mm

\*ANSI/APA/PRG 320: Standard for Performance-Rated Cross-Laminated Timber



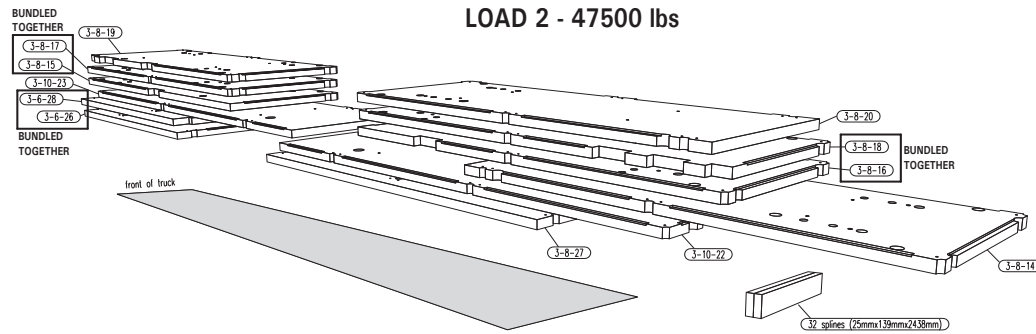

One of the innovative aspects of the Tallwood House project was its use of prefabricated components and just-in-time site delivery. The loading of each truck was planned using the unique identifying tracking numbers assigned to each element. The extensive prefabrication and sequence planning enabled completion of the mass timber structure and building envelope in just over nine weeks. It also reduced the construction waste, on-site noise, and transportation to the site as a significant amount of the work was done in a safer and controlled factory environment.

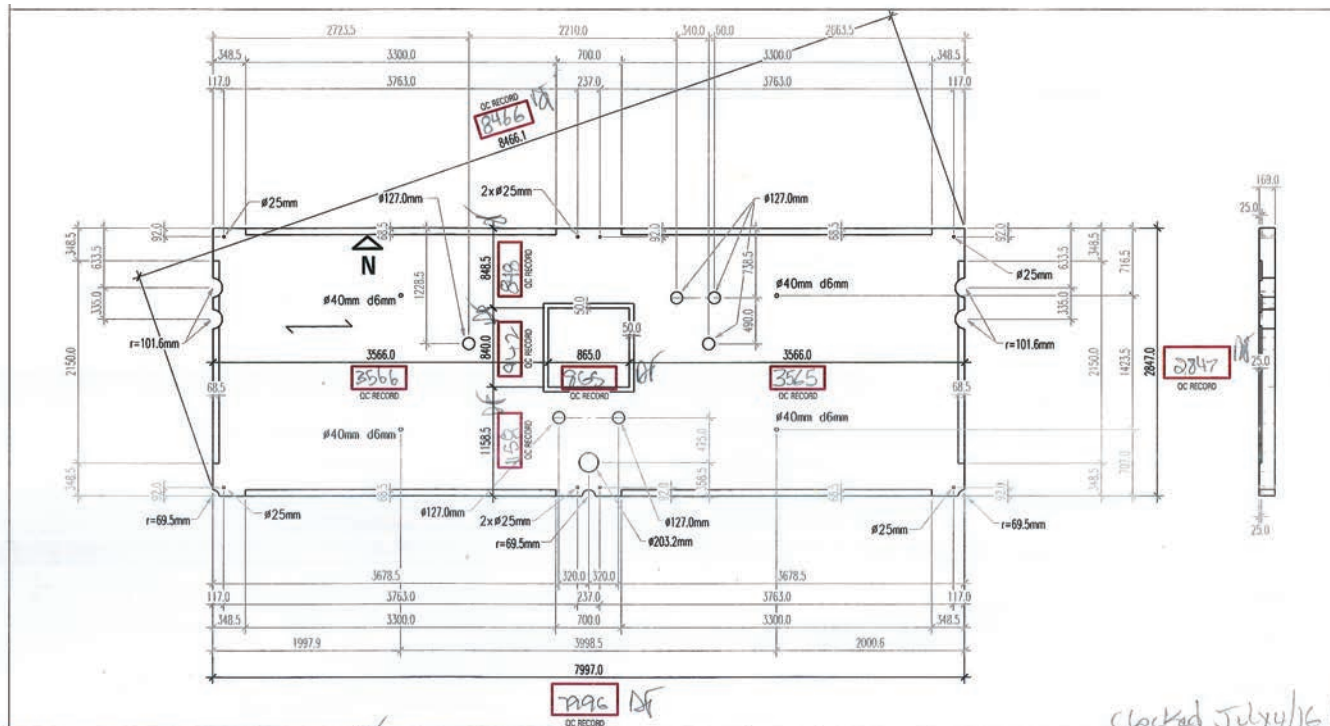
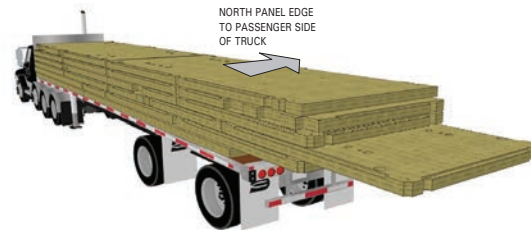

Structurlam Mass Timber Corporation

As part of the quality control process, the mass timber manufacturer and erector recorded the specified dimensions for each element and submitted them as their compliance record. The record included key indicators such as the dimensions, environmental conditions, the equipment used, damages, and modifications.

Factors such as dead and live loads could result in the axial shortening of the GLT and PSL columns as more floors were added to the building during construction. This shortening could damage the vertical mechanical services or the connections between the CLT panels and concrete cores. Therefore, the mass timber erector surveyed the height of the total structure as each level was installed in order to correct the structure's height when necessary. Height corrections were made by adding very thin steel shim rings at the column-to-column connections as authorized by the structural engineer. One of the mid-level surveys identified that the aggregate height of the floor panels was higher than it should be. This height differential was due to the columns being stiffer

than expected, which resulted in the axial shortening being less than estimated. To solve the problem, a site instruction was issued and all the top connections of one of the upper levels were sent back to the factory to be trimmed by 10 mm to realign the structure to the correct height.

To continue to monitor the vertical shortening of the structure over time, string gauges were installed to measure the floor-to-ceiling height of one representative GLT column per floor on levels seven through 18. Gauges were also installed on four different columns on levels two through six where there was a higher likelihood of shortening due to the increased loads.

*Axial shortening is the tendency of columns and vertical structural elements to compress after loading. Different materials compress at different rates. In mass timber, this tendency follows the direction of the wood fibres along the long axis. The structural design of Tallwood House took this into consideration, but overestimated the shortening of the GLT and PSL columns by a very small amount.*

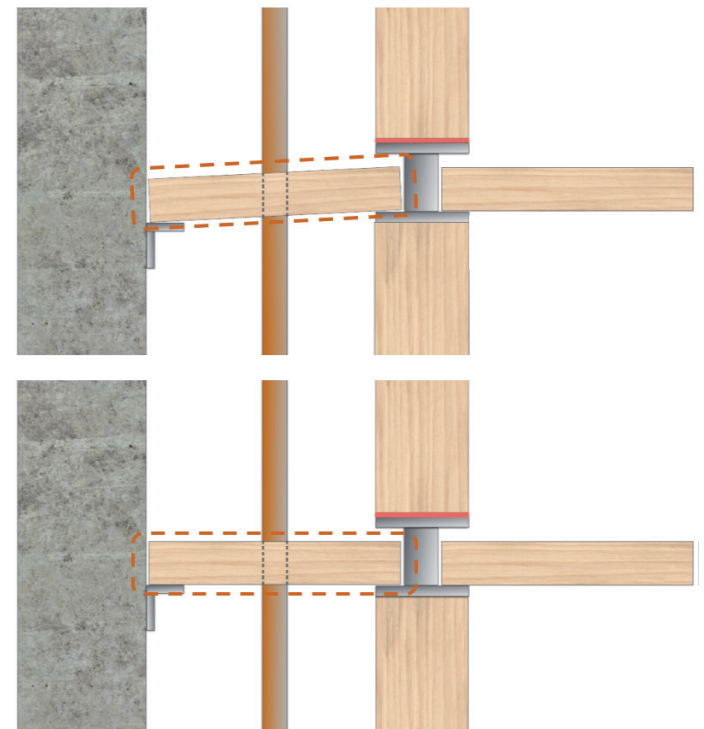

Acton Ostry Architects Inc.





## STANDARDS FOR STRUCTURAL PERFORMANCE

---

### Wood Elements

- ANSI/APA PRG 320 - *Standard for Performance-Rated Cross-Laminated Timber*
- CSA 0177 - *Qualification Code for Manufacturers of Structural Glued-Laminated Timber*
- CSA 0122 - *Structural Glued-Laminated Timber*
- CSA 086-14 - *Engineering Design in Wood*
- ASTM D2559 - *Standard Specification for Adhesives for Bonded Structural Wood Products for Use Under Exterior Exposure Conditions*
- ASTM D5456 - *Standard Specification for Evaluation of Structural Composite Lumber Products*

### Concrete Elements

- CSA A3001 - *Cementitious Materials for Use in Concrete*
- CSA A23.1 - *Concrete Materials and Methods of Concrete Construction*
- ASTM C260 - *Standard Specification for Air-Entraining Admixtures for Concrete*
- ASTM C494 - *Standard Specification for Chemical Admixtures for Concrete*
- ASTM C1017 - *Standard Specification for Chemical Admixtures for Use in Producing Flowing Concrete*
- CSA G30.18 - *Carbon Steel Bars for Concrete Reinforcement*
- ASTM A108 - *Standard Specification for Steel Bar, Carbon and Alloy, Cold-Finished*
- ASTM A767 - *Standard Specification for Zinc-Coated (Galvanized) Steel Bars for Concrete Reinforcement*
- ASTM A775 - *Standard Specification for Epoxy-Coated Steel Reinforcing Bars*
- ASTM A884 - *Standard Specification for Epoxy-Coated Steel Wire and Welded Wire Reinforcement*
- ASTM A1064 - *Standard Specification for Steel Wire and Welded Wire Reinforcement, Plain and Deformed, for Concrete*
- ASTM A1044 - *Standard Specification for Steel Stud Assemblies for Shear Reinforcement of Concrete*

### Steel Elements

- CSA G40.20 - *General Requirements for Rolled or Welded Structural Quality Steel*
- CSA G40.21 - *Structural Quality Steel*
- ASTM A53 - *Standard Specification for Pipe, Steel, Black and Hot-Dipped, Zinc-Coated, Welded and Seamless*
- ASTM A108 - *Standard Specification for Steel Bar, Carbon and Alloy, Cold-Finished*
- ASTM A325 - *Standard Specification for Structural Bolts, Steel, Heat Treated, 120/105 ksi Minimum Tensile Strength*
- ASTM F436 - *Standard Specification for Hardened Steel Washers Inch and Metric Dimensions*
- ASTM A563 - *Standard Specification for Carbon and Alloy Steel Nuts*
- ASTM F1554 - *Standard Specification for Anchor Bolts, Steel, 36, 55, and 105 ksi Yield Strength*
- ASTM F1852 - *Standard Specification for "Twist Off" Type Tension Control Structural Bolt/Nut/Washer Assemblies, Steel, Heat Treated, 120/105 ksi Minimum Tensile Strength*

### **DURABILITY**

UBC requires that all new academic and residential buildings on campus have a 100-year lifespan. Durability and the performance requirement for major building elements (especially the structure) are therefore a key concern. While there are many examples around the world of timber buildings that are 100 years or older, new engineered wood products, such as CLT and GLT, do not yet have the same demonstrated lifespans. Durability concerns in mass timber products encompass issues, such as excessive drying, cracking, moisture damage, and decay of the laminate adhesives used to glue the lumber together.

In order to ensure that the mass timber had sufficient durability, the project team conducted product testing to simulate an accelerated aging process. For example, the mass timber manufacturer conducted vacuum-pressure cycle tests during which product samples were subjected to extreme conditions by submerging them in a vacuum, applying high pressure, and drying them in an oven. The samples were assessed to check that any aging-related structural damage was within acceptable margins. The acceptable margin, in this case, was less than 10% delamination between individual pieces of laminated timber.

---

<sup>3</sup> “Brock Commons Tallwood House: Code Compliance”, *naturallywood.com*

<sup>4</sup> “Brock Commons Tallwood House: Construction Overview”, *naturallywood.com*

### **FIRE PROTECTION**

A major aspect of the design and construction of Tallwood House was management of the fire risks. The fire protection solutions were developed during the design phase and reviewed by an expert panel as part of the site-specific regulation process.<sup>3</sup> The primary fire protection measure for the building was to encapsulate the mass timber with a minimum of three layers of fire-rated gypsum board. This solution was based on the proven performance of this assembly in several previous full-scale fire tests conducted at the National Research Council of Canada’s facilities. Additional measures included the provision of an on-site backup water supply for the sprinkler and the firefighting water supply.

UBC’s Chief Building Official required fire tests of certain critical details, such as the proposed firestop for penetrations through the CLT panels. Both the UBC Building and Inspections unit and the project team fire engineer performed multiple site inspections to verify compliance with the building fire protection and life safety requirements. In some cases, officials required changes to certain fire protection measures, such as the detailing between the CLT floor panels and the envelope panels to ensure fire and smoke tightness.

To ensure fire safety measures were in place during the on-site construction activities, the project specifications required the construction manager to submit a comprehensive fire safety plan for approval by the City of Vancouver Fire Department and UBC’s Chief Building Official.<sup>4</sup>





Michael Elkan



Michael Elkan



### MOISTURE PROTECTION

Mass timber products are sensitive to moisture. Too little moisture content during manufacturing can affect the performance of the laminating adhesive, while too much moisture content results in the growth of mould. Therefore, the project specifications required adherence to moisture content levels as defined by the North American and Canadian standards for engineered mass timber products.

The building science consultant conducted several physical and simulation moisture tests to identify effective wood coatings that would minimize changes in moisture content levels during construction and over the building's operating life cycle. While coatings successfully lowered the moisture content during construction, the team learned that they prevented the concrete topping on the CLT panels from bonding adequately, which resulted in delamination in some areas. The issue was solved by mechanically re-attaching the concrete topping with screws.

A comprehensive water-management plan was developed to protect the mass timber during manufacturing and construction until the building was enclosed by the envelope. The mass timber manufacturer measured

and recorded the moisture content of each element at the production facility, covered and taped all holes, and wrapped the components in plastic covers that remained in place until just before installation on the building. On the construction site, the construction manager added extra taping to the mass timber connections, utilized a temporary drainage system to direct rainwater, and also measured the moisture content of each element on a frequent and regular basis. In addition, the envelope was installed concurrently with the mass timber, lagging no more than two floors behind the construction in order to protect the structure from the weather.

During construction, the team noticed that rainwater was able to travel through the seams between the laminate timber layers of the CLT panels. They also realized that the mass timber on the lower levels had higher moisture content than acceptable and that the encapsulating gypsum board had experienced water damage. To overcome these issues, the water-management plan was revised to make use of the concrete acoustic topping to prevent water from going further down.



RDH Building Science Inc.



RDH Building Science Inc.



RDH Building Science Inc.

Also, despite their high permeability, mass timber has a natural quality to dry quickly and return to acceptable moisture levels. Therefore, the wet elements were left exposed and fans were used to accelerate air circulation and the drying process of wet mass timber on the upper levels. The plywood splines that were used to join the CLT panels, however, took longer to dry partially because they were embedded within the CLT panels which limited air flow and slowed the rate of evaporation. As a consequence, the installation of the gypsum board was delayed and each wood element was tested to ensure that the moisture content was less than 15% before it was encapsulated.

Thanks to the measures in place for the on-site management of moisture and water issues during construction they were able to install all of the mass timber (including the concrete topping and the one layer of fire-rated gypsum board) and enclose it within the envelope panels two months ahead of the original schedule. These challenges, however, highlight the need for further research on moisture control, water management, and acoustic solutions for wood structures. Consideration of the moisture resistance and drying capability not just of the mass timber, but also of the other building materials will be an important factor in future tall wood projects. To continue to monitor the moisture levels of the mass timber structure during operation, sensors that automatically record moisture content and temperature data were installed on five CLT panels per level.

*Left to right: testing of CLT sealant options, moisture content testing of CLT panels in the mock-up, and moisture testing of PSL columns on site*

*Unwrapping of the CLT panels on site, just before installation into position on the building*







#### STANDARDS FOR TESTING ENVELOPE PERFORMANCE

---

- ASTM E283 - *Air leakage in a laboratory setting*
  - ASTM E331 - *Water penetration using static pressure in a laboratory setting*
  - AAMA 501.1-17 - *Water penetration using dynamic pressure in a laboratory setting*
  - ASTM E330 - *Structural performance under a uniform static pressure*
  - AAMA 501.5-17 - *Effects of thermal cycling in a laboratory setting*
  - AAMA 501.4-09 - *Effects of an earthquake or an intense wind event in a laboratory setting*
  - ASTM E1105 - *Water penetration in the construction field*
  - ASTM E1186 - *Air leakage site detection*
  - ASTM E783 - *Field measurement of air leakage*
  - ASTM E779 - *Air leakage by fan pressurization*
- 

ASTM: North American standards organization

AAMA: American Architectural Manufacturers Association

*To ensure the water tightness of the envelope, a standard water penetration test under air pressure was conducted on three sections of the building envelope after it was installed on the building. The tests had previously been conducted multiple-times on a mock-up to verify the performance of the new product design.*



## PERFORMANCE OF BUILDING ENVELOPE

The residential levels of Brock Commons Tallwood House use an envelope panel system that is composed of a steel frame with a laminate wood-fibre cladding. The layers of envelope panels from the frame to the exterior cladding were prefabricated and only the interior insulation and finishes installed on site. The envelope panels were manufactured using stringent tolerances to ensure a close and secure fit to each other and to the structure.

The project specifications required the manufacturer and installer to have demonstrated previous experience with prefabricated envelope systems. They were also required to have an adequate manufacturing facility and qualified personnel to design, engineer, detail, fabricate, and install the new envelope panels. To ensure the quality and performance of the envelope, the manufacturer and installer kept detailed logs of the various processes (manufacturing, storage, transportation, and installation) and of other factors, including environmental conditions, panel dimensions and tolerances, damage and missing elements on site, and any changes that could impact the overall performance of the installed envelope.

The envelope consultant reviewed and approved the shop drawings and installation plans, and conducted inspections at both

the manufacturing and construction sites. During field reviews, the consultant examined the product details, such as the thickness of the sealants and size of the window gaskets and requested improvements to ensure that the production and installation process exactly complied with the shop drawings. Examples of the improvements the consultant requested include adding anchors and fasteners to corner panels to reduce their movement and sealing the space between the envelope panels and the concrete cores to prevent water penetration.

As the envelope panels were a new product design, an independent testing agency conducted two sets of tests to ensure their performance. The first set of tests were performed on a full-scale mock-up in a laboratory setting and the second set on the actual panels on site. They tested for structural performance, air pressure and leakage, condensation, water penetration, thermal cycling, and other conditions that might be expected during the long-term operation of the envelope. The test results were evaluated based on common industry standards, but on stricter conditions for certain issues as dictated by the envelope consultant. As an example, the air pressure for the air leakage and water penetration tests were specified at a significantly higher level to ensure the envelope could withstand exposure to the windy and wet climate of the UBC campus.

## PERFORMANCE OF BUILDING SYSTEMS

Currently, UBC requires that all new buildings obtain a minimum certification of Leadership in Energy and Environmental Design (LEED) Gold with a specific requirement to undertake a process of enhanced commissioning in accordance with UBC's *Commissioning Technical Guideline*. The Tallwood House project specifications also outlined the requirements for commissioning the mechanical, electrical, plumbing, fire and life safety, elevators, and building management systems.

The enhanced commissioning process began in the pre-design phase and continued through design, construction, occupancy, and operation to ensure that UBC's performance expectations were documented, tracked, and achieved. A commissioning authority coordinated the different project team members and planned and managed the commissioning process, while electrical and mechanical commissioning agents represented the trades. The commissioning authority was involved early in the project, which allowed iterative review of the design and construction documents as they were developed to ensure that all the pertinent commissioning requirements were included. This step was crucial as it established clear expectations and informed the construction trades' activities and preparedness.

*Commissioning is the process of verifying that all the building systems have been designed, installed, and tested to ensure that they operate to the owner's performance requirements. Enhanced commissioning sets specific additional requirements for reviewing project documentation, verifying the system manuals, operational training, planning for periodic tests, reviewing the building system performance in the first 10 months of occupation, and developing an ongoing commissioning plan.*

During construction and the first year of occupancy, a series of start-up, functional, integration and seasonal tests as well as operational training have been taking place to confirm that the commissioned systems perform according to expectation and that staff understand how to operate and maintain them. The building systems in Tallwood House are similar to those in a conventional high-rise so the commissioning tests and training are fairly typical. Adaptations for the mass timber, such as the flexible connections for piping to accommodate movement between the concrete cores and the wood structure, and the on-site backup water supply for the sprinkler system were scrutinized with care but have also been used before by other projects in the region and were familiar to the industry.

A key benefit of enhanced commissioning is the ongoing review of the building systems during the first 10 months of operation. This will improve the effectiveness of the systems management and also support a better understanding of the long-term performance of a mass timber building through comparison and analysis of Tallwood House relative to other UBC student residences.

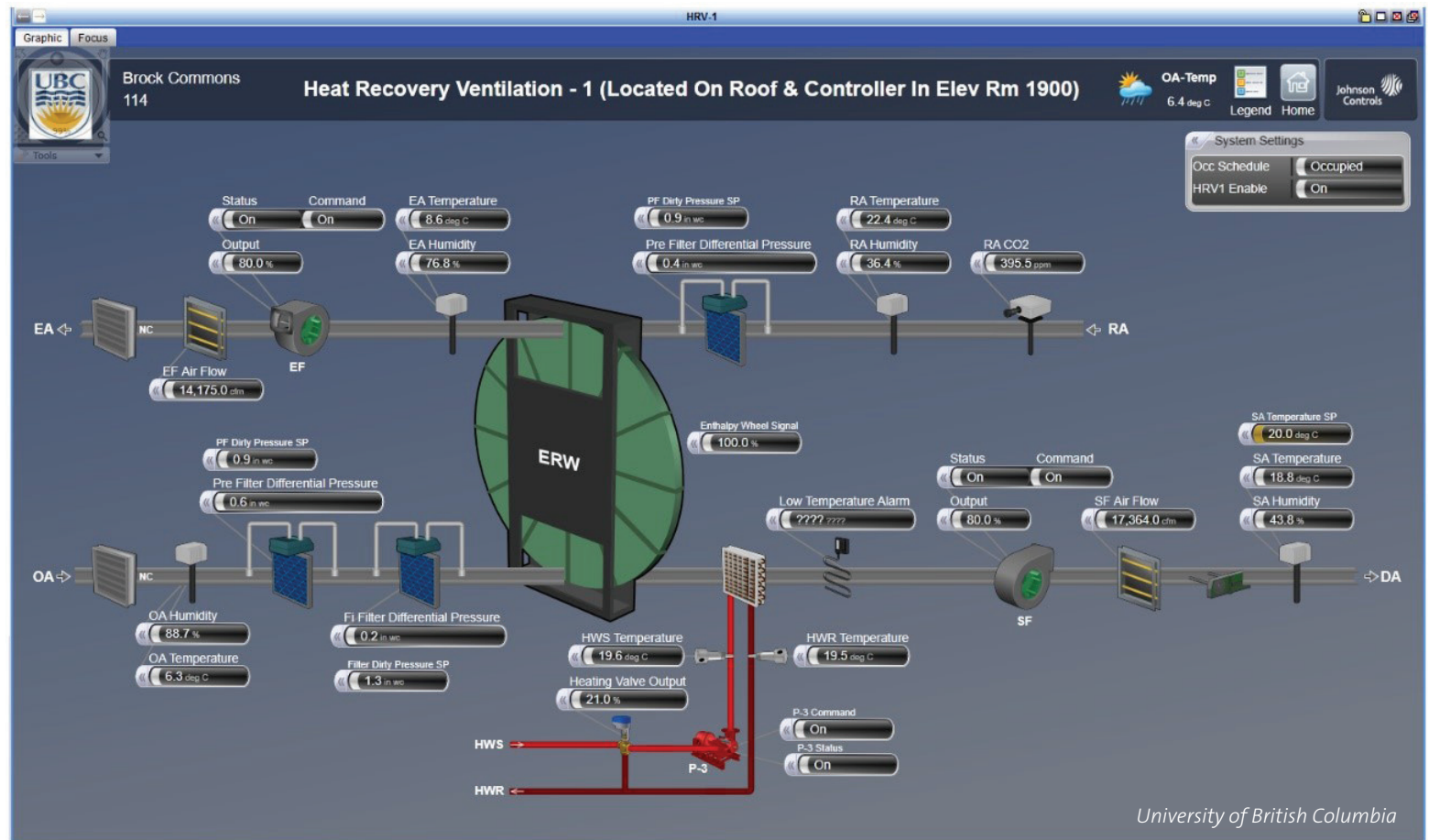

#### STANDARDS FOR TESTING BUILDING SYSTEMS AND SAFETY

- UBC – Commissioning Technical Guideline
- UBC – LEED V4 Implementation Guide
- ASHRAE Guideline 0-2005 – The Commissioning Process
- ASHRAE Guideline 1-1996 – The HVAC Commissioning Process
- LEED V4 – Reference Guide for Fundamental Commissioning
- LEED V4 – Reference Guide for Enhanced Commissioning
- SMACNA – H.V.A.C. Air Duct Leakage Test Manual
- CAN/ULC S1001-11 – Integrated Systems Testing of Fire Protection and Life Safety Systems and Fire Protection Commissioning

UBC Building Management System (BMS) display showing an HVAC air exchange system with an energy recovery wheel (ERW). The information displayed on and collected from the BMS allows the operators to assess systems performance and check data, such as air quality, temperature, and flow rates. The commissioning process ensures not only that the systems are working, but that the sensors and controls are too.



## COST ANALYSIS

### TOTAL PROJECT COSTS

The Tallwood House total project cost was \$51.5 million<sup>5</sup> and was completed on budget. By successfully coming in on budget and on schedule, Tallwood House demonstrated that hybrid mass timber high-rise buildings can be built economically. In addition to the cost of design and construction (described below), the project costs included project management, permits, landscaping, utility infrastructure, financing, and taxes.

### DESIGN COSTS

The design costs of Tallwood House were \$3.8 million. Of this total, 80% is attributed to the architectural and engineering services, which includes envelope, fire protection, and acoustic design as well as VDC modelling, energy modelling, and commissioning. The physical mock-up and lab tests of the innovative design solutions and materials choices made up only 5% of the total design costs.

### CONSTRUCTION COSTS

The total construction cost of Tallwood House was about \$40.5 million or \$248.90 per square foot. The cost of the structural elements, which includes concrete, mass timber, and metals was about 20% of the total construction cost. The next most expensive aspects were thermal and moisture protection (essentially the building envelope), mechanical and electrical systems, and finishes. These systems, which are largely independent of the structure together accounted for close to 50% of the total construction cost.

Tallwood House project demonstrated some of the financial and scheduling advantages of using a prefabricated mass timber structural system. The on-site erection crew, which averaged 10 workers, installed the mass timber in just over nine weeks (two floors per week). This was nine weeks faster than an equivalent concrete structure and there was no time lost due to injuries.

*“We estimate that the premiums for mass timber high-rise construction are expected to significantly drop in the future as the supply industry matures, the construction industry becomes more familiar, and the new solutions are optimized. The future projects benefit from the experiences in early adopter projects like Brock Commons Tallwood House as the lessons learned are being shared with the industry.”*

### CONSTRUCTION MANAGER

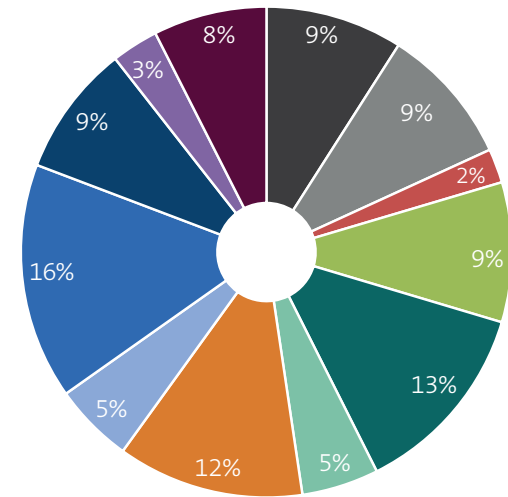

### MasterFormat Divisions

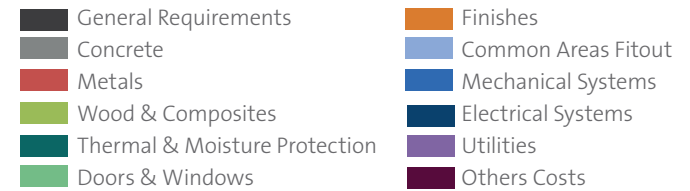

Tallwood House construction cost (MasterFormat<sup>6</sup> breakdown)

<sup>5</sup>All cost items in the report are in 2017 Canadian dollars.

<sup>6</sup>MasterFormat is a US and Canadian standard master list used for organizing information in construction projects. It is primarily used in specifications and detailed cost information, and to relate drawing notations to specifications.

### COST OF INNOVATION

As an early adopter of an innovative structural system the Tallwood House project required additional design activities as well as testing, regulatory approvals, and construction planning and coordination that would not be part of a conventional building project. These activities required additional resources from the project team and increased the cost of the project. The requirements of the site-specific regulation to ensure the safety and performance of the building also added to the costs.

The Tall Wood Building Demonstration Initiative provided about \$4.5 million in financial support for Tallwood House to help fund the cost of innovation. Out of the total contribution, \$1.5 million was used to offset the additional design costs, which included extra fees for specialized consultants, the site-specific regulatory approval process, and lab tests and mock-ups. The other \$3 million helped reduce the construction costs, which included material costs such as the encapsulating gypsum board and the cost of labour, which in some cases was higher due to the uncertainty of working on a new and unfamiliar building system.

The construction manager estimated the construction cost premium for innovation to be about \$2.7 million or 7% of the total construction cost in an analysis comparing Tallwood House to a (theoretical) equivalent high-rise with a conventional concrete structure. The difference in costs are not attributable to a single category, but are due to multiple variations across the entire project. For instance, the concrete topping and the encapsulating fire-rated gypsum boards, which were used primarily as acoustic and fire protection measures, make up over 60% of the innovation premium. The total cost of the structural elements, however, which include the categories of concrete, wood, and metal are similar between Tallwood House and the theoretical concrete equivalent.

*“To facilitate and expedite the site-specific regulation (building permit) process, Tallwood House took a very conservative approach to fire protection. Additional fire testing subsequently performed for other projects has shown that future mass timber projects will be able to use significantly less drywall for fire ratings. As the costs of concrete construction keep rising and the engineered mass timber manufacturing industry continues to mature, we can readily imagine a future in which these mass timber buildings become more economical to build than their concrete counterparts, in addition to being faster.”*

#### CONSTRUCTION MANAGER

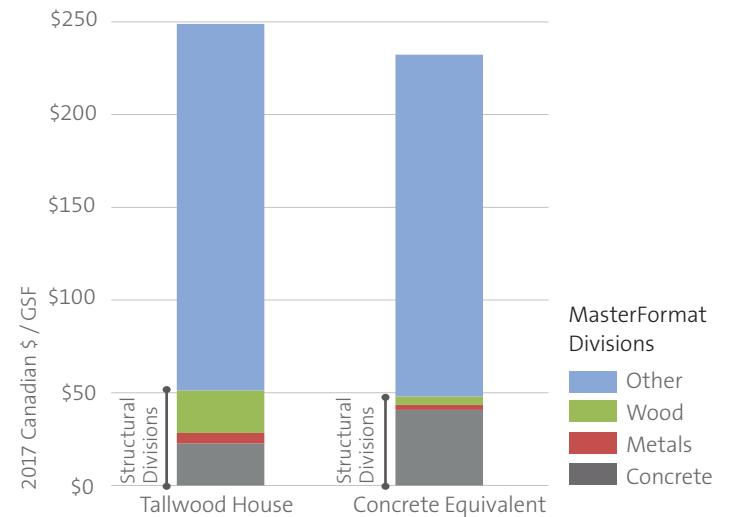

*Construction cost comparison between Tallwood House and a (theoretical) equivalent building with a concrete structure. The cost of the divisions which include the main structural elements (concrete, metal, and wood divisions in the MasterFormat breakdown) totalled about \$51/ft<sup>2</sup> for Tallwood House and about \$48/ft<sup>2</sup> for the theoretical concrete equivalent.*

## ENVIRONMENTAL IMPACTS ANALYSIS

Wood and, by extension, mass timber construction materials are generally recognized as offering considerable environmental benefits. However, to ensure the building as a whole has a desirable environmental performance it is important to consider the environmental impacts and benefits throughout the whole building life cycle. The building life cycle typically ranges from production to construction, use (operation, maintenance, and retrofits), and end of life (deconstruction, recycling, reuse, and disposal). Life Cycle Assessment (LCA) is an internationally accepted scientific method used to estimate the environmental impacts of a product or a system during its life cycle by measuring the positive and negative impacts of resource inputs and outputs (e.g., energy, water and materials).

An Environmental Building Declaration (EBD) is an in-depth building LCA conducted in accordance with the European whole-building LCA

standard *EN 15978* which is then verified by an LCA expert. It reports on a building's life-time environmental impact using a set of quantifiable indicators that are estimated based on information available from a building, such as material quantities, transportation methods and distances, and sources of energy used in production or operation. The EBD indicators are used as proxies to determine the long-term environmental hazards (such as climate change, degradation of non-renewable resources, and damage to ecosystems), which are harder to calculate or associate directly with specific activities during the life cycle of a building.

As more buildings undergo standardized EBDs, the results can be used to develop industry-wide baselines and benchmarks for the environmental impacts of whole buildings and, in turn, inform future designs, policies, and regulations.

### ENVIRONMENTAL IMPACT INDICATORS\*

- **Global Warming Potential (unit: equivalent kilograms of CO<sub>2</sub>)**  
An estimation of the mass of greenhouse gas (GHG) emissions that contribute to trapping heat in the earth's atmosphere and cause atmospheric warming. GHG in the construction industry is typically generated by fuel combustion.
- **Ozone Depletion Potential (unit: equivalent kilograms of CFC-11)**  
An estimation of the emitted mass of ozone-depleting gases, such as chlorofluorocarbons (CFC), hydrochlorofluorocarbons (HCFC), and halons that break down the protective ozone within the stratosphere and allow ultraviolet solar radiation to enter the earth's atmosphere. These gases have a negative effect on crops and human and animal health. Although their use has been largely regulated in the construction industry, these gases are often found in refrigerants.
- **Acidification Potential (unit: equivalent kilograms of SO<sub>2</sub>)**  
An estimation of the mass of acidic gases, such as nitrogen oxides (NO<sub>x</sub>) and sulphur dioxide (SO<sub>2</sub>) that cause acid rain and increase the acidity of the soil that, in turn, has a negative effect on ecosystems and human health, and can corrode buildings and artifacts. In the construction industry, these gases are typically emitted from fossil fuel combustion.
- **Eutrophication Potential (unit: equivalent kilograms of N)**  
An estimation of the mass of substances (such as nitrates, phosphates, and ammonia) that increase the nutrient level of surface water causing excessive algae growth that reduces oxygen in water and results in damage to aquatic ecosystems and increased water toxicity. The source of these substances can be industrial water discharges, leaching or runoff from agriculture, and pollution from sewers and drainage systems. In the construction industry, atmospheric nitrogen pollution comes from the burning of fossil fuels.
- **Smog Potential (unit: equivalent kilograms of O<sub>3</sub>)**  
An estimation of the mass of ground-level ozone that is produced by the chemical reaction of nitrogen oxides (NO<sub>x</sub>) (emitted from fossil fuel combustion) and volatile organic compounds (VOCs) (commonly found in solvents) when they are exposed to the heat of the sun. Ground-level ozone affects plant, animal, and human health.
- **Fossil Fuel Depletion Potential (unit: surplus mega Jules of energy)**  
A measurement of the additional energy required to extract increasingly inaccessible fossil fuels as a result of depleting these finite resources. In the construction industry, fossil fuels are used to generate energy and in materials such as plastics.

\*According to the European standard for environmental performance of buildings (EN 15978)



**TALLWOOD HOUSE LIFE CYCLE ASSESSMENT**

An Environmental Building Declaration (EBD) was prepared for the Tallwood House project. Although the building’s EBD addressed the entire life of the building (including the operation phase) the main focus was on the environmental impacts associated with building materials, which are commonly known as the embodied impacts. For this reason, this section only reviews the environmental impact of the building materials and not the building operations. The analysis used material quantity data from the construction manager’s bill of materials, the VDC model, and the issued-for-construction project documents.

Of all the indicators, the Global Warming Potential and the Fossil Fuel Depletion Potential of the building materials used in Tallwood House are the most significant. These two interdependent impact categories are primarily caused by fossil fuel combustion mostly during product manufacturing and transportation, and are typically the largest impact categories for buildings.

**TALLWOOD HOUSE ENVIRONMENTAL BUILDING DECLARATION\***

- Assessor: Athena Sustainable Material Institute
- LCA Standards: *EN 15978:2011* (LCA calculation methods for building), *ISO 14040: 2006* (LCA principles and frameworks), *ISO 14044:2006* (LCA requirements and guidelines)
- Life Cycle Inventory (LCI): Athena LCI database, US LCI database, Ecoinvent LCI
- Life Cycle Impact Assessment method: U.S. Environmental Protection Agency’s *Tool for the Reduction and Assessment of Chemical and other Environmental Impacts (TRACI v 2.1)*

\* “Brock Commons Tallwood House, University of British Columbia: An Environmental Building Declaration According to EN 15978 Standard”, Athena Sustainable Materials Institute, January 2018

*Life cycle stages of building materials used in Tallwood House*



**ESTIMATED ENVIRONMENTAL IMPACTS OF BUILDING MATERIALS OVER THE 100-YEAR LIFE CYCLE OF TALLWOOD HOUSE**

Impact Indicator	Unit	Total Impact
Global Warming Potential	kg CO <sub>2</sub> eq./m <sup>2</sup>	314.5
Ozone Depletion Potential	kg CFC-11 eq./m <sup>2</sup>	0.0000054
Acidification Potential	kg SO <sub>2</sub> eq./m <sup>2</sup>	1.9
Eutrophication Potential	kg N eq./m <sup>2</sup>	0.13
Smog Potential	kg O <sub>3</sub> eq./m <sup>2</sup>	29.3
Fossil Fuel Depletion Potential	MJ surplus/m <sub>2</sub>	409.5

As more tall wood buildings are developed, information like this EBD can be used to develop studies for similar building typologies and build a body of knowledge to inform future projects.

**GLOBAL WARMING POTENTIAL**

Due to rising concerns about climate change, greenhouse gas (GHG) emissions have become an area of focus at UBC and other jurisdictions and various policies, plans, and regulations have been developed to help achieve the campus emissions reduction targets. Currently, the majority of GHG emissions are from operational energy use, but as strategies to reduce operational fossil fuel consumption and emissions improve, the GHG embodied in the building components (i.e., emitted from their production, transportation, installation, and maintenance) becomes more significant.

Tallwood House’s emissions from operational energy and water consumption are estimated to be responsible for 84% of the total GWP, while the embodied GHG in the building’s materials contribute to the remaining 16%. The embodied impacts may seem relatively small, however the majority occur during the production phase. This means that reducing the GHG emissions from the raw material supply and production processes can contribute to the climate change mitigation plans at the beginning of the building’s life rather than throughout the building’s 100-year operational period.

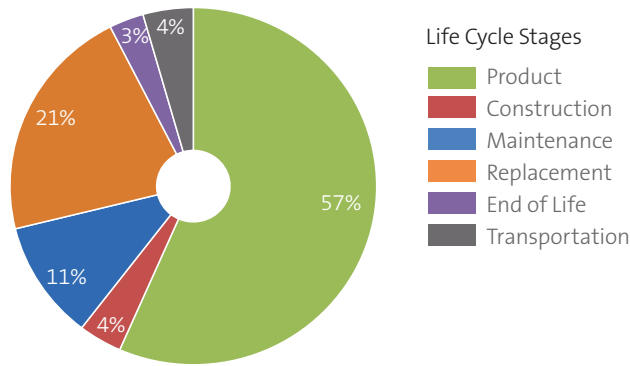

**BUILDING MATERIALS GLOBAL WARMING POTENTIAL BREAKDOWN BY LIFE CYCLE STAGES**

The majority of the embodied GWP impacts are produced during the production of the elements, which includes resource extraction and manufacturing of the original products and the products that replace them during the maintenance and renewal of the building.

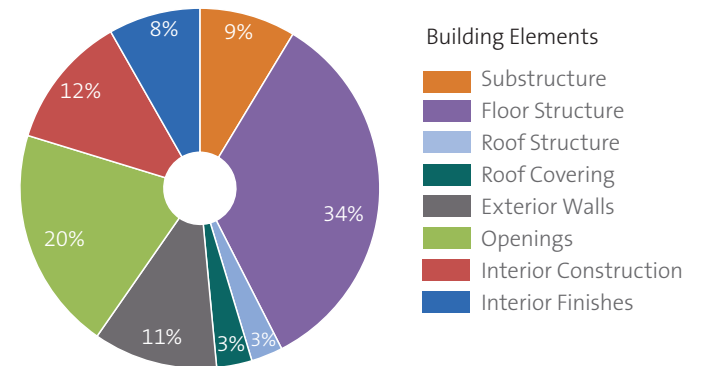

**BUILDING MATERIALS GLOBAL WARMING POTENTIAL BREAKDOWN BY BUILDING ELEMENTS**

The building structure (composed of the substructure, floor structure, and roof structure) is responsible for close to half of the building material related GWP impacts. The floor structure is comprised predominantly of the mass timber floors and columns, but also includes the steel connections, concrete ground floor and core structure, acoustic concrete topping, and the fire-rated gypsum board.

While the GWP in a standard EBD estimates the impact of the consumption and release of resources and chemicals during the lifetime of the building, some impacts extend beyond the building's life. Predominant among these is the potential for material reuse and recycling (which offsets the impacts of new materials) and carbon sequestration in certain materials. Carbon sequestration occurs in both wood and concrete. Carbon is sequestered in wood during photosynthesis as the tree grows. When the tree is cut down this carbon is stored in the wood products

until combustion or decay. Concrete gradually sequesters carbon from the atmosphere through a chemical process that occurs when it is exposed to air and moisture during its life cycle. A comparison of the estimated GHG emissions from wood used in the construction of Tallwood House to its potential to offset these emissions highlights the inherent ability of the mass timber to have positive environmental impacts that could result in a net positive impact.

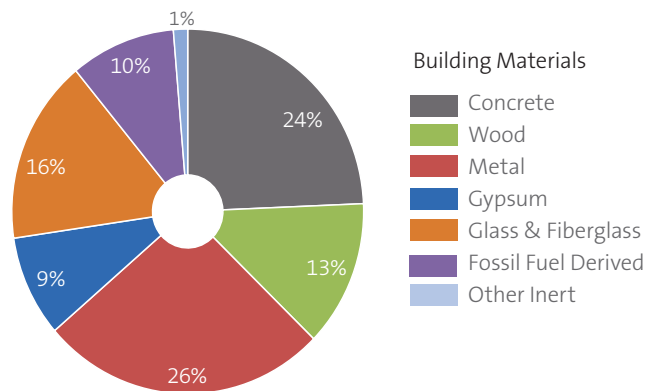

**BUILDING MATERIALS GLOBAL WARMING POTENTIAL BREAKDOWN BY BUILDING MATERIALS**

The GWP impacts are distributed broadly across the different types of building materials. Although the volume of wood in the building is only 35% less than the volume of concrete (about 2,500 m<sup>3</sup> and 3,400 m<sup>3</sup> respectively), the GWP contribution of wood is about 50% less than the GWP contribution of concrete.

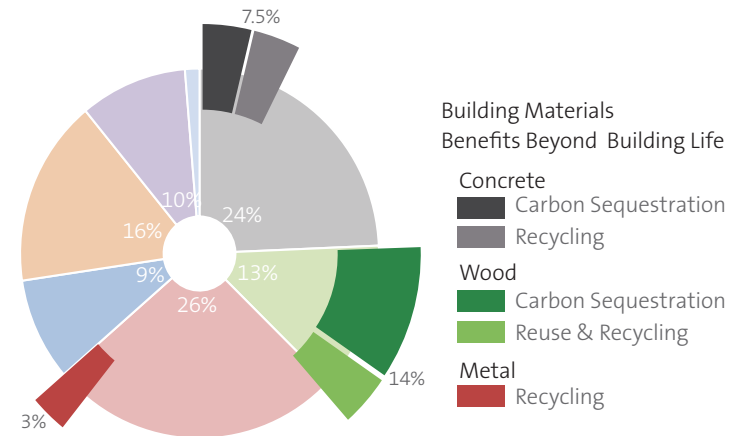

**BUILDING MATERIALS GLOBAL WARMING POTENTIAL IMPACTS VERSUS BENEFITS BEYOND THE LIFE OF BUILDING**

Environmental benefits of the building materials that extend beyond the building's lifetime help offset the negative impacts of the building. The carbon sequestration and potential reuse of wood are estimated to offset about 14% of the building GWP, whereas 13% of the negative building GWP is from wood elements. That means wood in this building has a net positive impact.







## INHABITANT COMFORT

The Department of Student Housing and Hospitality Services (SHHS) manages the student residences at UBC and has the mandate to provide safe, comfortable, and vibrant living spaces. While the innovative nature of the project required extra precautionary measures to ensure performance and safety (as dictated by the site-specific regulation), UBC found the repetitive structural design, prefabrication, and ease of mass timber construction particularly suitable for residence building projects. SHHS administers the largest university residence program in Canada with close to 12,000 beds, however, with a growing campus there is a strong need to rapidly increase the amount of on-campus student housing.

To continually improve the student experience, SHHS conducts an annual resident satisfaction survey with questions on topics such as staff accessibility, resident community and support programs, and noise levels in the buildings. UBC researchers added questions to this survey to inform the Post Occupancy Evaluation (POE) of Tallwood House. The intent of the POE is to examine the residents' satisfaction with various aspects of the building including the overall design, lighting, indoor air quality, thermal comfort, and acoustics. The POE will also include quantitative measurements to compare to the subjective inhabitant survey responses.

As a result of increased awareness and confidence in mass timber structures through projects like Tallwood House, there is growing interest in tall wood and an increase in such projects across Canada and North America. The research and learning from Tallwood House, which the team and UBC academics and operation staff continue to share, provides a valuable opportunity to improve knowledge of the long-term performance of mass timber, high-rise buildings. This in turn, will inform the effective design of mass timber structures more and serve to advance policies and regulations.

*“Living in Tallwood has been a great experience. Everything about the building is amazing and the community has made it feel like home!”*

---

STUDENT RESIDENT AT TALLWOOD HOUSE

## LESSONS LEARNED

The integrated design and code approval process for Tallwood House allowed the development of well-thought-out quality control and quality assurance procedures that were embedded in the project documentation.

- The site-specific regulations enabled the project team to access the expertise of independent professionals, authorities, academics, and researchers to provide input into the structural design and fire protection measures.
- Engaging the key project team members early allowed the feasibility, safety, and logistics expectations to be identified and clearly outlined in the drawings and specifications.
- Full-scale mock-ups and lab tests allowed an exploration of the safety, constructability, performance, and durability of various innovative elements in the project.

The project team successfully kept an effective balance between the innovative and exploratory approaches to performance and the use of established procedures, standards, and products.

- Despite the various innovative aspects of Tallwood House, the project drew on established North American standards and certifications to ensure the quality and performance of different building systems and products, such as the mass timber elements.
- Taking into account the unprecedented height of the structure and level of prefabrication, the authorities and design team mandated a higher degree of precision and accuracy to guarantee the building's safety and constructability.
- The detailed virtual design and construction model allowed coordination at greater levels of detail and tighter tolerances, and minimized unexpected issues during fabrication and construction.

The performance of a mass timber structure may be better understood and assessed when considered as an integrated part of the whole building's system.

- The water, fire, and acoustic performance solutions in Tallwood House were interrelated and the performance of other materials in addition to the mass timber defined the limits and opportunities. Consideration of the synergies between the fire, moisture, and acoustic management plans will benefit future projects.
- Wood has significant potential to reduce and offset the embodied environmental impacts. However, the wood benefits are only part of the environmental benefits and trade-offs across all the building materials. Consideration of the impacts of all major elements and materials as an integrated system provides opportunities for reducing the total environmental impact of buildings.
- Although Tallwood House had an estimated 7% innovation premium, the cost of the hybrid mass timber structure was comparable to an equivalent conventional concrete structure. The innovation premium is expected to drop as the industry becomes more familiar with mass timber construction and optimizes the new solutions.
- As more data is collected during the operation of Tallwood House, researchers can further assess the long-term performance of the structural, moisture, and acoustic performance of a high-rise mass timber structure as well as the inhabitants' satisfaction. This knowledge can contribute to improvements in projects and inform policies and regulations.

By coming in on budget and on schedule, Brock Commons Tallwood House demonstrated that tall wood and mass timber hybrid buildings can be built economically while also delivering community and environmental benefits.



**CASE STUDY**

This case study was prepared by the University of British Columbia's Centre for Interactive Research on Sustainability. The contributors are:

Angelique Pilon, PMP, MArch  
Zahra Teshnizi, MASA, CPHD  
Diana Lopez Behar, MSc  
Hailey Gooch, BFA

Information in this case study is based on the findings and documentation of the research team:

Francisco Caderon Cifuentes, BSc  
Ariel Li, MASc  
Sheryl Staub-French, PhD  
Thomas Froese, PhD

Research partners  
Sensible Building Science  
Athena Sustainable Materials Institute

**PROJECT CREDITS**

<b>OWNER</b> University of British Columbia, Student Housing and Hospitality Services	<b>ACOUSTICAL ENGINEER</b> RWDI AIR Inc.	<b>TIMBER SUPPLIER</b> Structurlam Mass Timber Corporation
<b>OWNER'S REPRESENTATIVE</b> University of British Columbia, Infrastructure Development	<b>CIVIL ENGINEER</b> Kamps Engineering Ltd.	<b>CONCRETE TRADE</b> Whitewater Concrete Ltd.
<b>PROJECT MANAGER</b> UBC Properties Trust	<b>LANDSCAPE ARCHITECT</b> Hapa Collaborative	<b>CONCRETE SUPPLIER</b> Lafarge
<b>ARCHITECT OF RECORD</b> Acton Ostry Architects Inc.	<b>BUILDING ENERGY MODELLING</b> EnerSys Analytics Inc.	<b>STEEL REINFORCING</b> LMS Reinforcing Steel Group
<b>TALL WOOD ADVISOR</b> Architekten Hermann Kaufmann ZT GmbH	<b>VIRTUAL DESIGN &amp; CONSTRUCTION MODELLERS</b> CadMakers Inc.	<b>STEEL SUPPLIER</b> Bar None Metalworks Inc.
<b>STRUCTURAL ENGINEER</b> Fast + Epp	<b>CONSTRUCTION MANAGER</b> Urban One Builders	<b>BUILDING ENVELOPE FABRICATOR</b> Centura Building Systems Ltd.
<b>MECHANICAL, ELECTRICAL, FIRE PROTECTION ENGINEER / LEED CONSULTANT</b> Stantec	<b>DESIGN-ASSIST TRADES</b> Structurlam Mass Timber Corporation Seagate Structures Whitewater Concrete Ltd. Trotter & Morton Building Technologies	<b>ROOFING TRADE</b> Raven Metapro Systems Ltd.
<b>BUILDING CODE &amp; FIRE ENGINEERING</b> GHL Consultants Ltd.	<b>COMMISSIONING CONSULTANT</b> Zenith Commissioning Consulting	<b>MECHANICAL TRADE</b> Trotter & Morton Building Technologies
<b>BUILDING ENVELOPE &amp; BUILDING SCIENCES</b> RDH Building Science Inc.	<b>TIMBER ERECTOR</b> Seagate Structures	<b>ELECTRICAL</b> Protec Installations Group
		<b>DRYWALL</b> Power Drywall Ltd.

**IMAGE CREDITS**

<b>PHOTOS</b> Various photographers: naturallywood.com Acton Ostry Architects Inc. Urban One Builders RDH Building Science Inc. Seagate Structures Fast + Epp	<b>DRAWINGS</b> Structurlam Mass Timber Corporation  <b>GRAPHS</b> University of British Columbia Sensible Building Science Athena Sustainable Materials Institute
--	--

**OTHER CASE STUDY RESOURCES (WWW.NATURALLYWOOD.COM)**

Brock Commons Tallwood House: Design & Preconstruction Overview	Brock Commons Tallwood House: Construction Overview
Brock Commons Tallwood House: Code Compliance	Brock Commons Tallwood House: Construction Modelling
Brock Commons Tallwood House: Design Modelling	





INNOVATION PARTNERS



Natural Resources  
Canada

Ressources naturelles  
Canada

# OVERVIEW

naturally:wood®