

INNOVATION IN HYBRID MASS TIMBER CONSTRUCTION

BROCK COMMONS TALLWOOD HOUSE

DESIGN AND PRECONSTRUCTION OVERVIEW



Early version of the design.
Render by Acton Ostry Architects Inc.

"At the end of the day, this building is just exceedingly simple. Besides the fact that it has wood slabs and wood columns, it's just like any other building. And that's the secret. I believe that the success of this project has been everyone saying 'We are just going to keep this project as simple as possible!'"

PRINCIPAL ARCHITECT



PROJECT CONTEXT

The University of British Columbia, one of Canada's premier universities, is located on a forested peninsula on the west side of Vancouver. It is a community of academic, residential, commercial, and agricultural functions and facilities, with a strong focus on sustainability and the integration of research, teaching, and operations.

The student population is growing. In order to provide more housing, reduce commuting, and nurture a more sustainable and vibrant community, the University is developing campus hubs. These mixed-use high-rise hubs consist of student housing, academic facilities, and other social and service amenities for the whole community.

The University's most recent hub development features the Brock Commons Tallwood House, an innovative hybrid high-rise that, at 54 m high (18 storeys), stands as the tallest mass timber building in the world after completion in 2017. Brock Commons provides 404 beds for students, in studios and quad units, with public amenity spaces on the ground floor and a lounge on the top floor.

Brock Commons' hybrid structural design ensures the building's performance and safety. The foundation, ground floor, and stair/elevator cores are reinforced concrete, while the superstructure is composed of cross-laminated timber (CLT) floor panels supported on parallel strand lumber (PSL) and glue-laminated timber (GLT) columns with steel connections. The building envelope is comprised of prefabricated, steel-stud frame panels with wood-fibre laminate cladding, and a traditional SBS (styrene-butadiene-styrene) roof assembly on metal decking.

The University of British Columbia is already at the forefront of the global movement to revitalize mass timber construction and be innovative in the use of new wood products in its academic and operational buildings, but the construction of a residential high-rise is a first for the University. Brock Commons is pioneering recent advances in engineered timber products and building techniques, demonstrating that wood is a viable option for high-rise applications while creating unique research and learning opportunities related to the design, construction, operation, and inhabitation of a tall wood building in North America.

FACTS

- Height is 54 m (18 storeys)
- Site area is 2,315 m²
- Gross areas is 15,120 m²
- Footprint is about 15x56 m, totalling 840 m²
- Typical floor-to-floor height is 2.81 m for the mass timber structure on the upper floors, and 5 m on the ground floor

FRONT COVER

Brudder
KK Law

BACK COVER

KK Law





GROWING INTEREST IN TALL WOOD BUILDINGS

Globally, a number of mass timber buildings have been constructed during the last decade. The majority of these buildings utilize hybrid structural systems that combine concrete, steel, and a variety of engineered wood products—including cross-laminated timber panels, laminated veneer lumber (LVL), laminated strand lumber (LSL), and glue-laminated timber. These buildings, predominantly located in Europe, range from 8 to 14 storeys and serve a mix of commercial, residential, and institutional uses. However, interest in the use of mass timber building products for mid-rise and high-rise construction in North America is expanding, as demonstrated by the growing number of innovative projects and incentives. This growth is driven by technical advances in the design, manufacture, and construction of products and structural systems, as well as by recognition of the environmental advantages of wood as a renewable resource that sequesters carbon.

In 2013, Natural Resources Canada collaborated with the Canadian Wood Council to launch the Tall Wood Building Demonstration Initiative. It provides financial and technical support for encouraging the design and construction of tall wood buildings in Canada. The Initiative's overall objective is to link scientific advances with technical expertise to showcase the application, practicality, and environmental benefits of structural building solutions that are innovative and wood-based.

Brock Commons was one of the tall wood building designs selected for construction through the competitive process of the Tall Wood Building Demonstration Initiative.



SOME MODERN TALL WOOD BUILDINGS

Name	Location	Year	Storeys
TREET	Bergen, Norway	2016	14
Forte	Melbourne, Australia	2012	10
Banyan Wharf	London, U.K.	2015	10
Cenni di Cambiamento	Milan, Italy	2013	9
Strandparken	Stockholm, Sweden	2014	8
Puukuokka	Jyväskylä, Finland	2015	8
Wood Innovation and Design Centre	Prince George, Canada	2014	6
St. Dié-des-Vosges	France	2014	8
Pentagon II	Oslo, Norway	2013	8
Lifecycle Tower One	Dornbirn, Austria	2012	8
Holz8	Bad Aibling, Germany	2011	8
Contralaminada	Lleida, Spain	2014	8
Bridport House	London, U.K.	2010	8
Tamedia Office Building	Zürich, Switzerland	2013	7
Wagramer Strasse	Vienna, Austria	2013	10
Panorama Giustinelli	Trieste, Italy	2013	10
Maison de l'Inde	Paris, France	2013	10



Wood Innovation and Design Centre
Prince George, Canada
Michael Green Architecture

DESIGN PROCESS

COMPOSITION OF THE DESIGN TEAM

As a student residence, Brock Commons is operated by the University's department of Student Housing and Hospitality Services. Because Brock Commons is a capital project, the University's Infrastructure Development department serves as the owner's representative, and UBC Properties Trust is the project manager for design, construction, and commissioning.

To anchor the project's design team, and to initiate conceptual studies, the University engaged an experienced structural engineer familiar with mass timber construction and the campus. A Vancouver-based architect was selected from several local and international submissions. The winning proponent partnered with an Austrian firm that has expertise in tall wood buildings and which acted in an advisory role. Most of the additional consultants were also familiar with the campus's previous projects.

A construction management company was engaged for the preconstruction and construction phases through two independent and public Request for Proposal processes. Specialty trades, specifically the timber supplier, timber erector, and the concrete forming and placement companies, were also involved in design-assist roles to ensure the solutions were optimized for materials sourcing and constructability. Because mass timber is not a common construction typology for mid-rise and high-rise buildings in North America, the regional network of fabricators that can supply mass timber products on the large scale required by the project is limited. The project team considered the specific sourcing and procurement options, including overseas suppliers, when designing and planning the building's execution.

Acton Ostry Architects Inc.



CREATION OF A SITE-SPECIFIC REGULATION

The University of British Columbia is a single legal entity with sole jurisdiction over its land, buildings, and infrastructure, i.e., it operates similarly to a small municipality in regulating building and development. As with any municipality, the building projects at the University of British Columbia are governed by a number of overlapping policies, codes, and regulations that are established at the local, provincial, and national levels.

The primary regulation governing tall wood building construction at the University is the *British Columbia Building Code 2012*. Brock Commons is classified as a residential occupancy (Group C) with assembly spaces (Group A-2).

At 18 storeys, or 54 m in height, the vision for Brock Commons did not adhere to the *British Columbia Building Code 2012*. The Code allows combustible construction—e.g., wood—for a residential building only if it is no more than 6 storeys and/or 18 m high, has a maximum building area of 1,200 m², and is fully sprinklered. The project team and the University's Chief Building Official worked with the British Columbia Building and Safety Standards Branch to draft the *UBC Tall Wood Building Regulation* (September 2015). This is a site-specific regulation that exempts the Brock

Commons project from some parts of the *British Columbia Building Code*—such as the parts regarding size limitation on combustible construction—and substitutes different technical requirements that apply only to Brock Commons. The intention is to ensure occupant health and safety protection is equal to or better than that provided by the Code for non-combustible construction of this size.

The development of a site-specific regulation involves a rigorous review process. For Brock Commons Tallwood House, this began with peer reviews of the design concepts and proposed technical strategies conducted by third-party structural engineering firms. The Building and Safety Standards Branch managed the regulation development process. The process included design review by two expert panels on the topics of structural performance and fire safety, and collaborative problem solving that involved the Building and Safety Standards Branch, the University's Chief Building Official, and the design team. The process allowed feedback and input from reviews and regulation deliberations to be incorporated in the final design.

PANEL DEFORMATION ANALYSIS

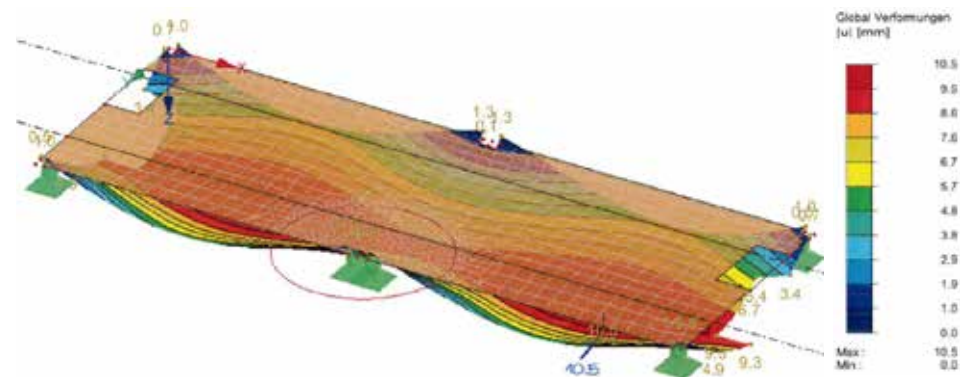

Deformation analysis was performed as part of the third-party structural peer reviews, by merz kley partner AG.

HIGHLIGHTS OF THE DESIGN PROCESS

Based on its experience with previous projects, the University's Student Housing and Hospitality Services had already developed a preferred suite layout and overall building design for student residences. The project-specific parameters, including the site, building area, and height restrictions, also provided a clearly defined framework for the design team. The design process officially began in November 2014 and was completed in October 2015.

The team adopted several key strategies to address the challenges of designing Brock Commons within the constraints.

Integrated design workshop

A 3-day integrated design workshop, held in January 2015, was attended by core project team members, including the architect of record and the advisory architect; structural, mechanical, and electrical engineers; code consultants; the virtual modeller; the construction manager; and the design-assist trades. The team visited precedent buildings on campus, including other student residence hubs, and the team reviewed options for the various design components and building systems. The workshop's key focus was to analyze multiple structural approaches in terms of costs, constructability, and impacts on the building's engineering systems, which resulted in consensus on the use of the GLT/PSL column and CLT panel solution.

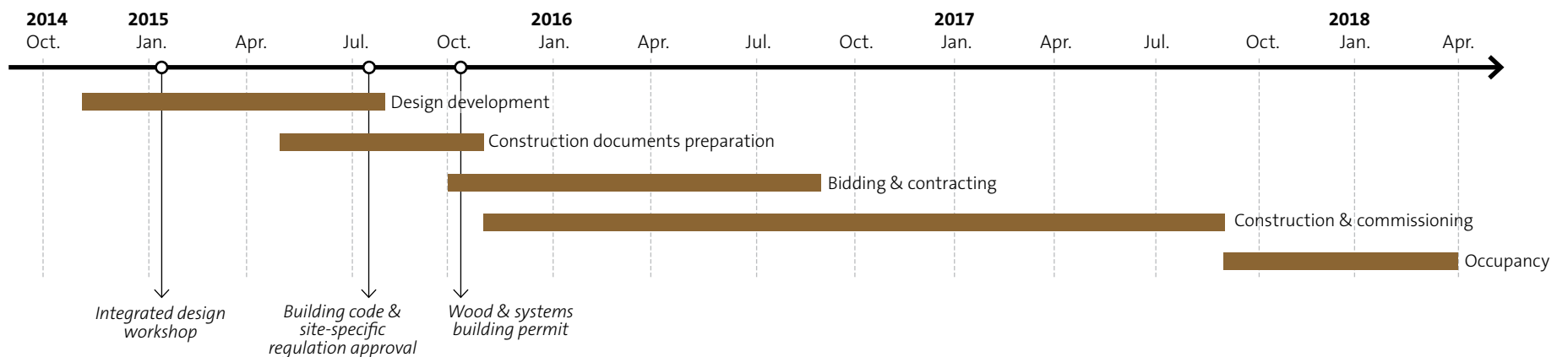



Virtual design and construction modelling

Based on consultants' design drawings and models, the virtual design and construction modeller developed a highly detailed, 3D virtual model of Brock Commons. The model helped the project team develop the design and coordinate between the different disciplines. During the workshop, virtual modelling was used to visualize the impacts and estimate the cost of each proposed solution in real time, which greatly facilitated the decision-making process. During subsequent stages of the design process the virtual model was used for clash detection, constructability reviews, quantity takeoffs, trades communication ahead of the bids, 4D planning and construction sequencing, and digital fabrication of prefabricated elements.

Although the virtual design and construction modeller contributed to the design optimization, the responsibility and liability for the building design were always clearly kept with the professionals of record in each discipline. The drawings and specifications prepared by those professionals are the legal contract documents for the project.

Physical mock-up

As part of the design phase, a full-scale mock-up of a section of the building was built to test and validate the viability and constructability of the designed solutions for the hybrid structural system and prefabricated envelope panels. It was built by the design-assist trades, thus allowing them to further refine the building assemblies as well as the installation processes. Key components were digitally fabricated using the virtual model, which provided an opportunity to test the transfer of information between the virtual design and construction modeller and the mass timber supplier. The mock-up also provided an opportunity to test different materials and finishes—such as the concrete topping, wood sealer, and exterior cladding—in real-world conditions.

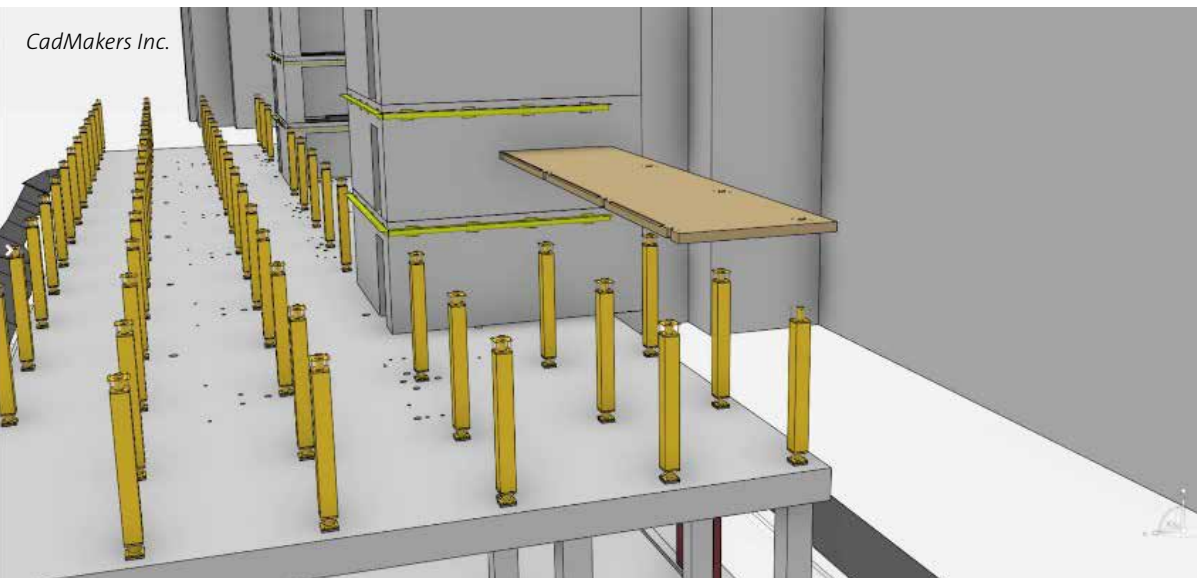

CadMakers Inc.

FINAL DESIGN OF A GROUNDBREAKING HIGH-RISE

GENERAL STRUCTURAL APPROACH

Given the pioneering nature of Brock Commons as a hybrid high-rise building, a key design driver was to employ tried and tested solutions that are commonly available, code compliant, and in accordance with the Canadian Standards Association or other recognized standards. Therefore, while on the whole the project is innovative, the project team worked to develop components and parts that are as simple and as standard as possible.

Brock Commons' structural system is designed as a hybrid configuration. The foundations, ground floor, and building cores are reinforced, cast-in-place concrete. The concrete second-floor slab acts as a transfer slab between the concrete and the wood structures and allows the ground-floor structural grid to be independent of the wood structural grid. The structural gravity load system of floors 3 to 18 consists of GLT columns and CLT floor panels, with PSL columns replacing the GLT in high-load areas on floors 2 to 5. Point connections between columns and slabs consist of hollow structural section steel assemblies.

The decision to adopt a hybrid structure was driven by the design requirements and tight approval deadlines. The complexity of providing the necessary support for the lateral forces associated with a tall wood structure made it unfeasible to pursue mass timber solutions for the building cores due to the amount of time that would be needed to create the innovative designs and secure approvals for them. Also, on the ground floor, the use of a concrete structure allowed for high clearances and large spans in Brock Commons' public spaces and provided non-combustible spaces to house large mechanical and electrical services.

BUILDING ELEMENTS

CLT panels	
Volume	1,973 m ³
Quantity	464 panels
Weight	954 tonnes
Glulam/PSL columns	
Volume	260 m ³
Quantity	1,298 columns
Volume of concrete saved	2,650 m ³
Avoided GHG emissions (compared to a concrete building of similar size)	679 metric tonnes

ENGINEERED WOOD ELEMENTS



Cross-laminated timber (CLT)



Glue-laminated timber (GLT)



Parallel strand lumber (PSL)

HYBRID STRUCTURAL SYSTEM

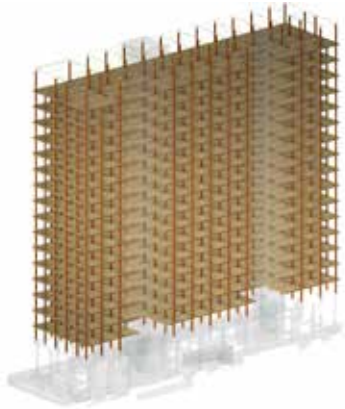

Wood structure components
CLT panels, and GLT and PSL columns



Cast in place reinforced concrete structure
Ground-floor columns, transfer slab, and concrete cores

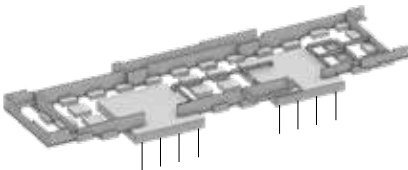

Cast-in-place reinforced concrete foundation
Spread footings, perimeter strip footing, and raft slabs

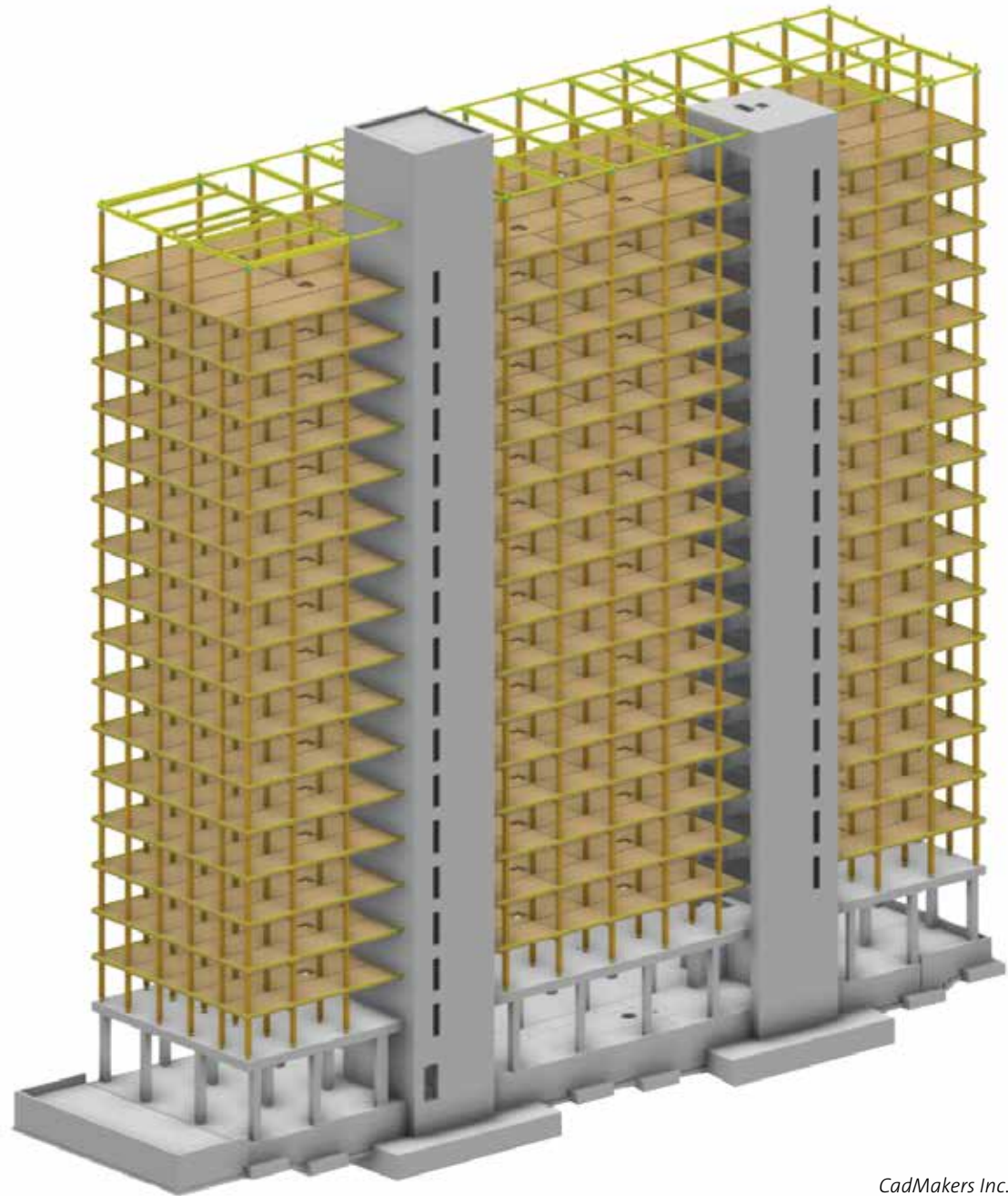

CadMakers Inc.

FOUNDATION AND SUPERSTRUCTURE

The building foundation is composed of 2.8×2.8×0.7-m reinforced spread footings and a 250-mm-thick wall on a 600×300-mm-thick strip footing at the perimeter of the building. Below each core is a 1.5-m-thick raft slab that includes soil anchors with 1,250-kN tension force capacity.

The choice of a mass timber superstructure will result in a building significantly lighter than a comparably sized concrete building,¹ thus Brock Commons requires smaller and less costly footings. However, the lower mass also results in less inertia and less resistance to overturning, which are key considerations in a seismic zone such as coastal British Columbia. The structure is therefore designed to ensure that all lateral forces are adequately transferred first to the building cores and then to the raft slabs.

Brock Commons' superstructure is comprised of reinforced concrete columns on the ground floor and a concrete transfer slab on the second floor, two reinforced concrete cores, mass timber slabs and columns on the upper floors, and a steel perimeter beam at each floor. The beam stiffens the edge of the perimeter CLT panels and supports the building envelope. The concrete column grid measures 5×5 m while the wood column grid measures 4×2.85 m.

The CLT panels are 169 mm thick and made of five layers of dimension lumber. The 29 CLT panels per floor are joined together by a

140×25-mm-thick plywood spline nailed or screwed to each panel. A 40-mm concrete topping increases the acoustic insulation properties and provides fire protection during construction. Most of the columns are GLT. Some PSL columns are used on floors 2 through 5 at the center of the building, for additional compression strength. Typically the column cross sections are 265×265 mm on floors 2 to 9, and 265×215 mm on floors 10 to 18.

The advantages of the adopted structural solution are the elimination of beams, the relative light weight of the CLT panels, and the speed of erection due to prefabrication. The main disadvantage is the limited material supply, because only one local supplier manufactures CLT panels; sourcing from European suppliers was considered, but the cost of shipping was prohibitive. The panels are four different lengths: two 6-m-long panels located at the cores, two 10-m-long panels located at the cores, nineteen 8-m-long panels, and six 12-m-long panels.

The roof structure consists of metal decking on steel beams supporting a traditional SBS membrane roofing system. A steel roof system rather than a wood one was selected in order to mitigate any water-damage issues, such as wood rot and mildew, and to reduce the risk of structural damage if a leak went undetected for some time.

¹Chen, K.M.G. and A. Harmsworth. *A Look at the 18 storey tall wood building: UBC student residence at Brock Commons Tallwood House*. Newsletter, Fall 2015. GHIL Consultants Ltd., Vancouver, BC.

Although there are only four standard panel sizes in the project, most panels on a single floor are unique due to the configuration of the mechanical, plumbing, and electrical openings.

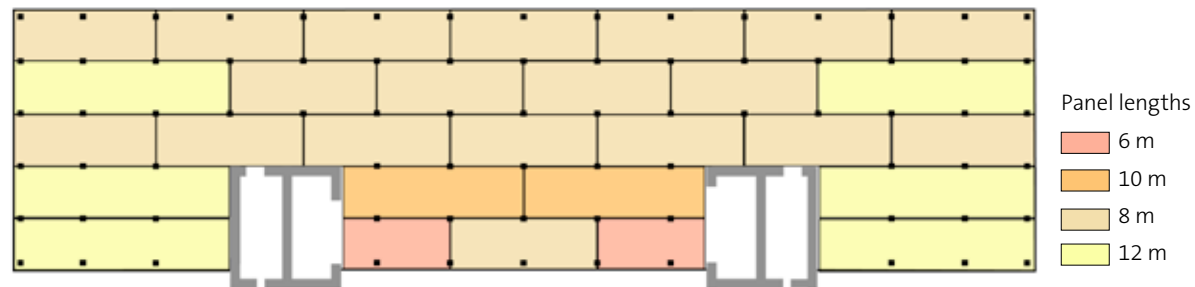

“We divided the structure into gravity loads and lateral loads, because for the lateral loads it was very clear early on that there was going to be a concrete core. That decision was made because we only had so much time to design the project, and the cores themselves would have taken up all of it. Also, from a code perspective, to get a wooden core through [the approval process] wouldn’t have been feasible within our time frame. There are enough 18-storey concrete buildings out there that everybody knows how to deal with concrete cores.”

STRUCTURAL ENGINEER



KK Law



Brudder

STRUCTURAL CONNECTIONS

Structural connections, in particular the ones between the wood and concrete elements, are designed to address key challenges: meet structural loading requirements while accommodating different reactions by different materials; minimize transmission of vibration through the building; meet the required fire ratings for various assemblies; coordinate penetrations for the building systems with the connection locations; and ensure the precise and accurate layout of anchor bolts, angles, and other connection components between the time of prefabrication and the time of on-site construction.

Columns to concrete transfer slab

A hollow structural section steel base with top and bottom plates is anchored to the second-floor concrete transfer slab by cast-in-place bolts and is levelled with grout and levelling nuts. Threaded steel rods are glued into the GLT/PSL column during fabrication and are bolted to the top steel plate.

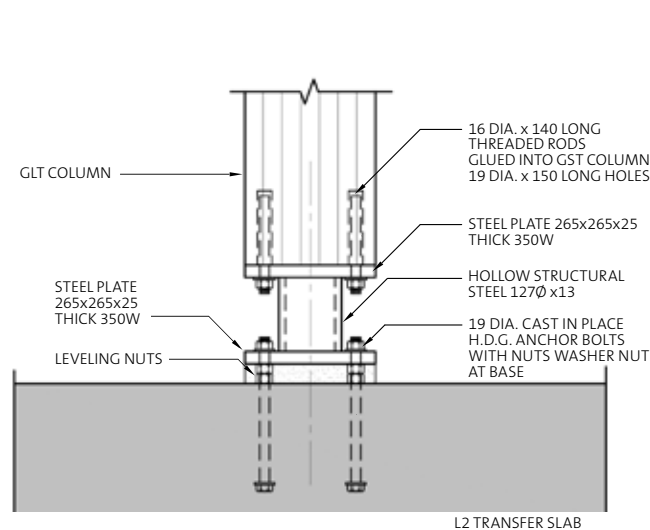

Column to column and column to CLT panel

A round hollow structural section is welded to a steel plate embedded at the top and the bottom of each column, by means of threaded rods epoxied into the column. The connection assemblies at the base of each column have a smaller-diameter hollow structural section that fits into the one at the top of the lower column. The CLT panels rest on top of the lower columns and are bolted to the steel plates by four threaded rods. This type of connection allows vertical load to be transferred directly from column to column, while supporting the vertical and shear loads of the CLT panels.

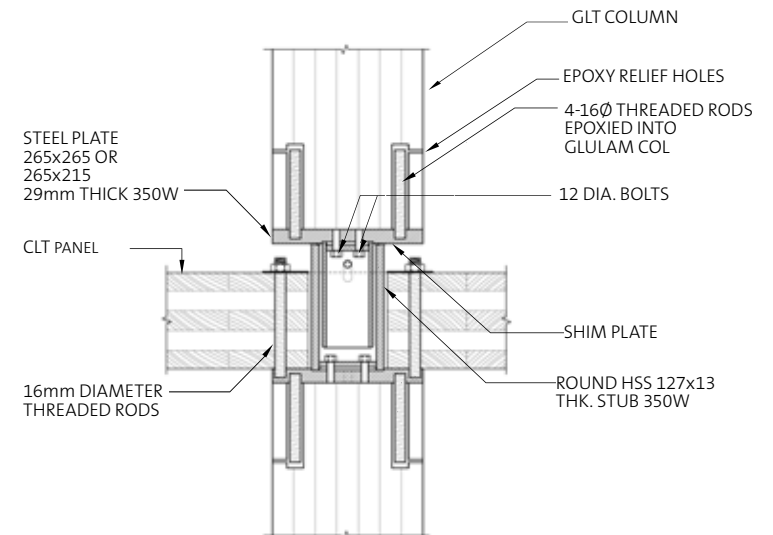

CLT panel to concrete core

Panel-to-core connections—The CLT panels are supported by and screwed to a steel angle that is welded to a steel plate anchored to the concrete core. This connection accommodates the transfer of both vertical and shear forces at the connection point and the differential settlement between the wood and concrete portions of the structure.

Drag straps—Steel drag straps are used to transfer lateral loads from the floors to the cores. The straps are screwed to the top of the CLT panels and are welded to faceplates that are bolted to the concrete cores. The size of the drag straps varies based on a strap's position within the building, with larger plates used on higher floors. Similar drag-strap details are also employed along the perimeter of the building to connect the exterior edge of the CLT panels back to the concrete cores.

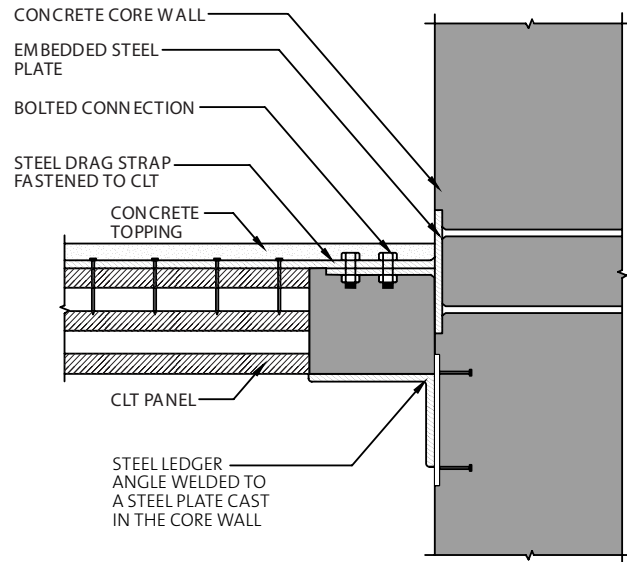

GLT column to steel roof

Steel roof beams are welded to a round hollow structural section that is run through by two 19-mm bolts. The hollow structural section is welded to a bottom plate bolted to the GLT columns by threaded rods that are glued in during prefabrication.

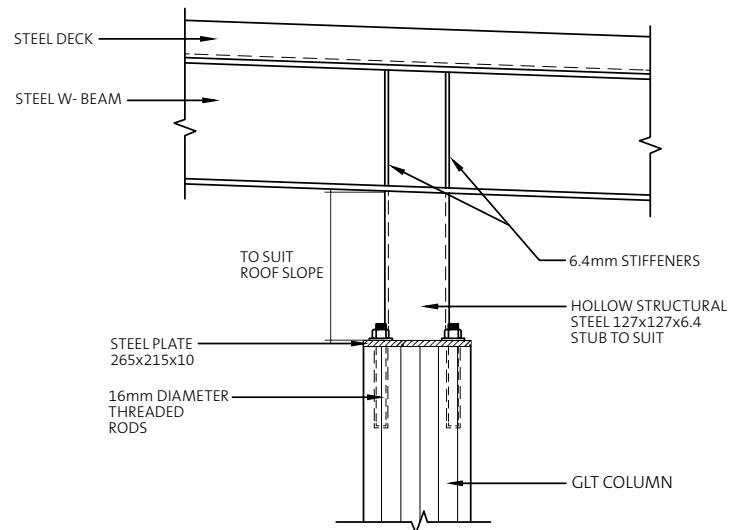



BUILDING ENVELOPE

The ground floor of Brock Commons is enclosed by a glass curtain wall system. A three-layered CLT panel canopy with a double-folded, standing-seam, metal roof provides coverage for pedestrians.

On the upper floors, the building envelope is a prefabricated panel system with an R-16 minimum thermal resistance. Each panel is composed of a structural steel stud system; fibreglass batt insulation; a wood-fibre, laminate-panel, rainscreen cladding system; and pre-installed window assemblies. The panels measure 8 m wide (to span two structural grids) by 2.81 m high (to span one story). The 127×127×13-mm steel perimeter angle, which is attached at each floor, supports the panels.

This prefabricated envelope system allows the building to be rapidly enclosed as the structure is erected, in order to protect the wood components from the weather. The prefabricated portion is composed of the rainscreen cladding system up to the steel studs. The vapour barrier, batt insulation, and the interior layer of drywall will be applied on site.

“We are applying an immediate closure type of strategy, whereby we don’t go [beyond a few] levels of structure until we have closed the building envelope of the current level. That decision has also driven a large, panelized format for the building envelope.”

CONSTRUCTION MANAGER

On the upper floors, the building envelope is a prefabricated panel system.

BUILDING SYSTEMS IN WOOD CONSTRUCTION

The mechanical, electrical, and plumbing systems are relatively conventional and typical for a residential building of this size. Brock Commons is connected to the University's Academic District Energy System, which provides thermal energy for space heating of public areas and domestic hot water. Units are heated by electric baseboards, which automatically turn off when windows are opened; the operable windows allow for space cooling and natural ventilation.

As a general strategy, building systems are consolidated in centralized locations and have highly coordinated distribution pathways to reduce penetrations in the CLT panels. For example, horizontal distribution for both supply and exhaust air ducts occurs immediately below the roof; these ducts then branch to vertical shafts located between units and service the suites on all floors. The kitchen exhaust ducts use charcoal filters to clean and recirculate the air, thus eliminating any horizontal duct runs to the exterior of the building as well as penetrations through the building envelope.

All horizontal distribution of systems, such as conduits and pipes, must be surface mounted to the underside of the CLT panels and require coordination of routes and headroom clearances. Distribution pathways were planned during the design phase in order to facilitate the design

of the penetrations and cutouts into the digital fabrication of the CLT panels. These aspects of the design were captured in the virtual design and construction model, and were tested during the construction of the full-size mock-up.

The building systems are also designed to be flexible in order to accommodate settlement and variation in structural movements, given that the wood structural elements will settle and shrink at different rates than the concrete cores. The domestic hot water system is designed with cross-linked polyethylene piping instead of the traditional copper. Polyethylene piping is regarded as a more durable material than copper; it is flexible and thus does not require as many fittings and connections, which decreases the risk of leaks. Other flexible design strategies include the use of braided stainless steel connections, expansion compensators, expansion joints, flexible ducts and pipe connectors, and suspended sanitary and storm stacks at every fourth floor.

In the case of a leak, the ability to prevent and mitigate water accumulation within units or interior assemblies was also considered. Each unit has a floor drain in the bathroom—which is not standard practice in North American residential construction—and a highly visible water-shutoff panel.



The detailed virtual model allowed the team to identify potential clashes and constructability issues and it helped the team coordinate the layout for pre-fabrication of the CLT panels.

INTERIOR LAYOUTS AND CONSTRUCTION

The interiors of Brock Commons are of similar programming and layout as other precedent residence projects on campus. The ground floor includes administration; food services; amenity functions such as social and study spaces for students; and mechanical, electrical, and other service rooms. The upper floors house sixteen single and two quad residential units per floor, and a lounge area is on the eighteenth floor. Standard suite layouts that had been developed for a previous residence were tweaked to allow for the wood structure. For example, the mechanical, electrical, and plumbing systems are consolidated through shafts, and services

closets are stacked to minimize the number of penetrations through the prefabricated CLT panels.

The design of interior elements is driven by the need to provide adequate fire resistance and acoustic separation. Encapsulation of the wood structural columns and floor panels achieves a 2-hour fire resistance rating. Internal demising walls are designed to provide a 2-hour fire resistance rating between suites and a 1-hour fire resistance rating between the units and the corridor.

TYPICAL FLOOR ASSEMBLY

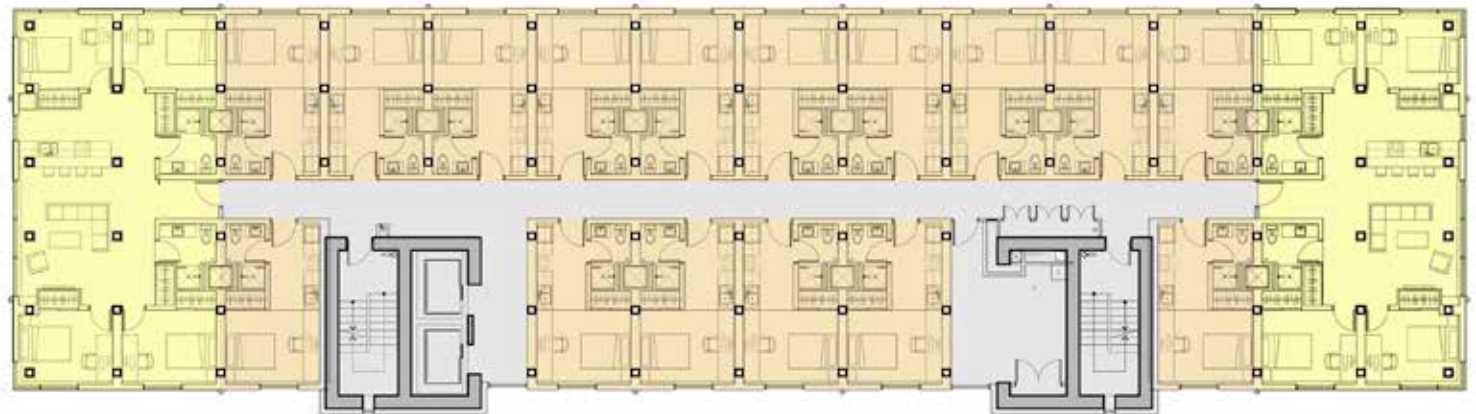

*A typical floor consists of 16 single and 2 quad residential units per floor.
Detail by Acton Ostry Architects Inc.*

- Quad unit
- Studio unit
- Service area

The acoustical insulation is designed to be between 52 and 54 STC (Sound Transmission Class) for floor assemblies and between 50 and 62 STC for wall assemblies. Additional strategies to deal with sound absorption and to reduce vibrations include: the application of a concrete topping on the CLT panels to increase the weight and stiffness of the floor assembly, the incorporation of an air space into the ceiling assembly, and the addition of carpet tile and resilient flooring to reduce floor hardness.

TYPICAL CLT PANEL FLOOR ASSEMBLY

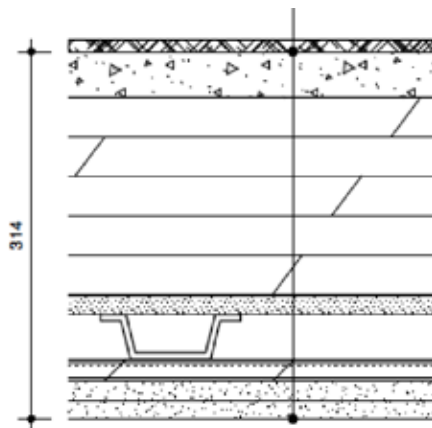

Assembly

- Floor finish
- 40-mm concrete topping
- CLT slab panel
- 16-mm GWB type "X"
—moisture resistant
- 38-mm steel hat track
- 19-mm steel res bar
@ 400 mm o.c.
- 16-mm GWB type "X"
- 16-mm GWB type "X"
- Interior finish

ENCAPSULATION OF WOOD ELEMENTS
Acton Ostry Architects Inc.

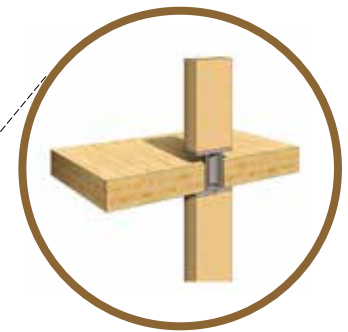
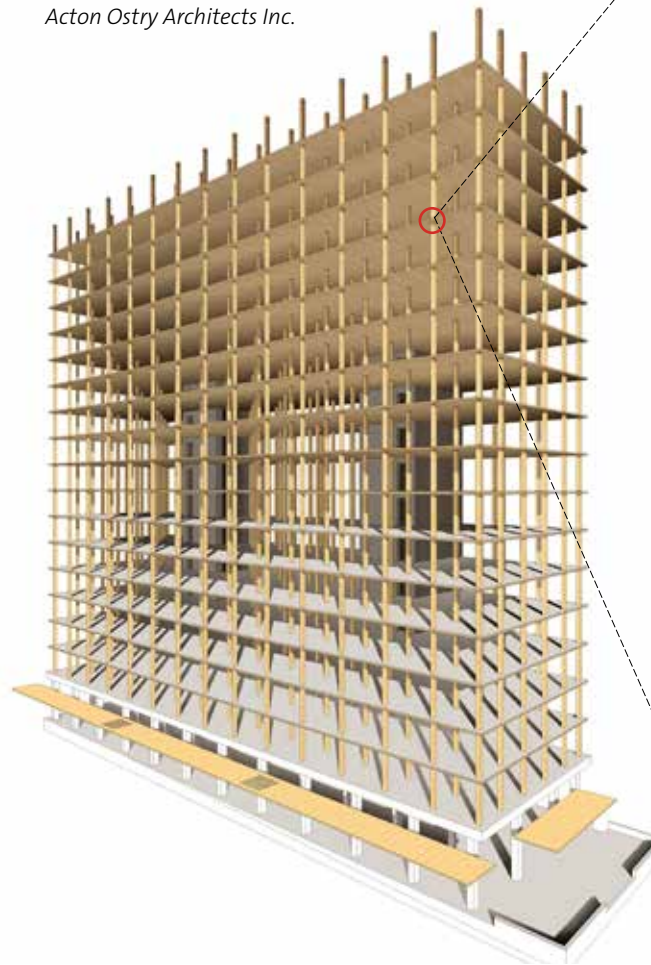

Steel connection—
column to column and
column to CLT panel



Partial encapsulation of CLT
panel, for fire safety during
construction

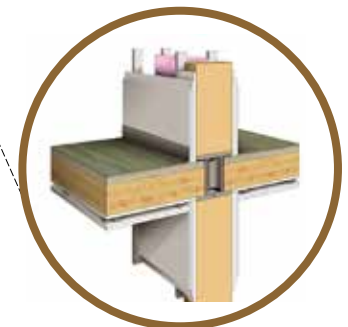

Complete encapsulation of the wood
structure after construction provides
a 2-hour fire resistance rating

Hybrid structure of mass timber and concrete,
with floor concrete topping

Fire resistance rating

--- 2 hours

--- 1 hour

■ 20,000-litre
water tank

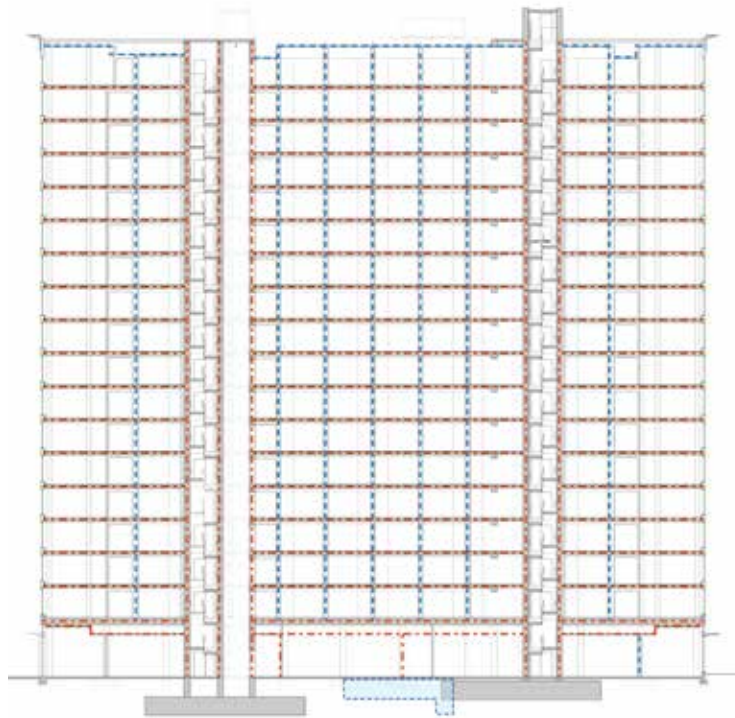

Fire protection measures. Detail by GHL Consultants Ltd.

FIRE DETECTION AND SUPPRESSION

The fire alarm system is single stage and addressable, and includes audible and visual signal devices as well as transponders and relays to the Vancouver fire department, which has a firehall on campus. The fire suppression system is also electronically supervised and monitored to signal the fire department.

The fire suppression system consists of an automatic sprinkler system, a standpipe system, and a water curtain for areas where 100% unprotected openings are required (i.e., the ground-floor study and social spaces that are exposed to the parkade). Sprinkler heads are recessed to mitigate the possibility of being accidentally hit and damaged or set off. The exterior canopies and loading dock are covered by non-freezing sprinkler heads.

The systems, including the standpipe, are standard for a Vancouver-area high-rise, with the exceptions of a fire pump on emergency power and a 20,000-litre tank to act as an on-site, backup water supply. The tank capacity represents approximately 30 minutes of water supply for the residential sprinklers and increases the reliability of the automatic sprinkler system to close to 100%.

BUILDING MONITORING

Because this hybrid type of construction is new, there are few actual performance data on which to base design decisions and code regulations. As part of the demonstration nature of Brock Commons, a monitoring system was installed to collect data on the performance of engineered wood products and hybrid structural systems in a high-rise building. The data from Brock Commons, and the research that will be conducted with it, are expected to contribute to the creation of performance and building safety standards for future tall wood buildings.

Three aspects of building performance that pose specific challenges to tall wood buildings will be monitored.

- Moisture content of the CLT panels—Sensors installed within the CLT panels will measure the variation of moisture content in the panels throughout their entire life cycle, including during fabrication and installation, as well as during use in the building.
- Vertical settlement, including elastic shortening, moisture-related shrinkage, and creep—Sensors installed along key structural elements on all floors will monitor differential movement between individual components and total vertical settlement of the building.
- Horizontal vibrations due to wind (and, potentially, earthquakes)—Accelerometers located at the top, bottom, and midpoint of the building will monitor acceleration rates, lateral vibrations, and other displacements.



LESSONS LEARNED

As a demonstration of a novel type of building, the planning of the Brock Commons Tallwood House has required high levels of commitment from the design team, and the ability to respond to some new and unpredictable challenges and considerations.

- Unwavering commitment to the development of a successful mass timber solution on the part of the owner provided a critical foundation for the team to work from.
- Having clear project goals and objectives that were aligned across all the team members ensured that everyone was working towards the same type of solutions and had the aim of achieving the best for the project.
- Encouraging the common motivations of the individual team members—such as innovation, market leadership, and carbon reduction—helped to strengthen the team alignment and support the collective goals.

The building design, and especially the hybrid structural solution, was developed for code approvals and constructability as well as performance. This meant that the design phase had to integrate the traditional building design with detailed planning for the construction phase.

- Approaching the project as an integrated design process, including the use of activities like workshops and informal “open door”

discussion, enabled and supported stronger collaboration between the disciplines.

- Involving the construction trades in the design process—in “design-assist” roles—made it possible to have input and critique of assumptions and proposals with regard to constructability and supply chain issues such as materials sourcing, coordination, costs, and scheduling.
- Strategically maximizing prefabrication opportunities within the building created a strategy for streamlining the construction processes, while taking advantage of the additional expertise present during design.

The overall simplicity of the design of Brock Commons is broadly recognized as being key to the project’s success. The design approach emphasized the project as a whole rather than viewing it as a set of separate building components, systems, or applications.

- Simple solutions reduced the time and effort expended on design details and unnecessary material costs, and they facilitated construction and shortened project delivery time.
- A simple design also contributed to the affordability, safety, and efficient operation of the building.



CASE STUDY

This case study was prepared by the University of British Columbia's Centre for Interactive Research on Sustainability. The contributors are:

Angelique Pilon, PMP, MArch, LEED BD+C
Aletha Utimati, PMP, MEng
Jessica Jin, MScP

Information in this case study is based on the findings and documentation of the research team:

Erik A. Poirier, PhD
Thomas Tannert, PhD
Azadeh Fallahi, BSc
Manu Moudgil, BSc
Sheryl Staub-French, PhD

PROJECT CREDITS**OWNER**

University of British Columbia,
Student Housing and Hospitality Services

OWNER'S REPRESENTATIVE

University of British Columbia,
Infrastructure Development

PROJECT MANAGER

UBC Properties Trust

ARCHITECT OF RECORD

Acton Ostry Architects Inc.

TALL WOOD ADVISOR

Architekten Hermann Kaufmann ZT GmbH

STRUCTURAL ENGINEER

Fast + Epp

MECHANICAL, ELECTRICAL, FIRE PROTECTION ENGINEER / LEED CONSULTANT

Stantec

BUILDING CODE & FIRE ENGINEERING

GHL Consultants Ltd.

BUILDING ENVELOPE & BUILDING SCIENCES

RDH Building Science Inc.

ACOUSTICAL ENGINEER

RWDI AIR Inc.

CIVIL ENGINEER

Kamps Engineering Ltd.

LANDSCAPE ARCHITECT

Hapa Collaborative

BUILDING ENERGY MODELLING

EnerSys Analytics Inc.

VIRTUAL DESIGN & CONSTRUCTION MODELLERS

CadMakers Inc.

CONSTRUCTION MANAGER

Urban One Builders

DESIGN-ASSIST TRADES

Structurlam Products LP

Seagate Structures

Whitewater Concrete Ltd.

COMMISSIONING CONSULTANT

Zenith Commissioning Consulting

IMAGE CREDITS**PHOTOS**

naturally:wood

Research Team

Fast + Epp

RENDERS & TECHNICAL DRAWINGS

Acton Ostry Architects Inc.

Fast + Epp

CadMakers Inc.

OTHER CASE STUDY RESOURCES (WWW.NATURALLYWOOD.COM)

Brock Commons Tallwood House: Code Compliance

Brock Commons Tallwood House: Design Modelling

Brock Commons Tallwood House: Construction Overview

Brock Commons Tallwood House: Construction Modelling

Brock Commons Tallwood House: Performance Overview





INNOVATION PARTNERS



Natural Resources
Canada

Ressources naturelles
Canada

OVERVIEW

naturally:wood®